



Primary School Curriculum



Science

Social, Environmental and Scientific Education

Teacher Guidelines



DUBLIN
PUBLISHED BY THE STATIONERY OFFICE

To be purchased directly from the
GOVERNMENT PUBLICATIONS SALE OFFICE
SUN ALLIANCE HOUSE
MOLESWORTH STREET
DUBLIN 2

or by mail order from
GOVERNMENT PUBLICATIONS
POSTAL TRADE SECTION
4-5 HARCOURT ROAD
DUBLIN 2
(Tel: 01-6476834-5; Fax: 01-4752760)
or through any bookseller

Design Consultancy:	Bradley McGurk Partnership
Designed by:	The Identity Business
Photography:	Christy McNamara
Typesetting:	Spectrum Print Management
Printed by:	Mozzon Giuntina - Florence and Officine Grafiche De Agostini - Novara



Science

Social, Environmental and Scientific Education

Teacher Guidelines

Contents

Section 1

Science in the primary curriculum

The nature of science	2
Science in a child-centred curriculum	3

Section 2

The content of the science curriculum

Basic structure and terminology	6
Content strands	6
Skills development	16
<i>Working scientifically</i>	17
<i>Designing and making</i>	21

Section 3

School planning for science

Curriculum planning	26
Organisational planning	29

Section 4

Classroom planning for science

The teacher's planning	32
Planning a unit of work	36
Integrated learning	44

Section 5

Approaches and methodologies

Organising and managing the science lesson	52
A variety of approaches	53
Learning about plants and animals	57
<i>Approaches to outdoor exploration and investigation</i>	58
<i>Approaches to investigating habitats</i>	61
<i>Investigations with living things</i>	76
<i>Investigating the processes of life in plants</i>	83
Approaches to learning about light	86
Approaches to learning about sound	92
Approaches to learning about electricity and magnetism	96
Approaches to learning about forces	107
Approaches to learning about humans	117
Approaches to learning about materials	123
Approaches to learning about heat	129
Environmental awareness and care	130
Approaches to designing and making	133
Using information and communication technologies	140
Looking at children's work	142

Section 6

Appendix

Resources for teaching and learning science	148
Source references for curriculum and guidelines	152
Glossary	154
Membership of the Curriculum Committee for SESE	166
Membership of the Primary Co-ordinating Committee	167
Acknowledgements	168



Section 1

Science in the primary curriculum

Science in the primary curriculum

Science is a human endeavour that depends on the creativity and imagination of people as they reflect critically to make sense of their experience.

Practical investigation is central to scientific activity.

Children will learn to investigate the world around them through

- observing
- hypothesising
- predicting
- investigating and experimenting
- testing
- analysing.

The nature of science

Science is concerned with the development of knowledge and understanding of the biological and physical aspects of the world. Scientific activity is the process through which such knowledge and understanding are developed. For children, as for scientists, science involves testing, changing or confirming ideas about how things are and how they work. Scientific theories are used to explain observed phenomena or to predict events. These ideas and theories are subject to review and change and will be modified as new evidence comes to hand.

Science is a human endeavour that depends on the creativity and imagination of people as they reflect critically to make sense of their experience. It is important that learning activities promote curiosity and enjoyment, so that pupils develop a lasting interest in science. The placing of science within the context of social, environmental and scientific education (SESE) will promote its relevance and help children to develop informed attitudes towards scientific and environmental issues.

For many teachers, primary science has its roots in nature study and environmental studies. Studies of human biology, plants and animals, and the natural and human environments are already incorporated in many classroom activities. The aim of these guidelines is to assist teachers and schools in building on children's interests and curiosity about the biological and physical world

while at the same time incorporating experimental and investigatory skills in their work. These guidelines will also provide assistance for schools in developing aspects of science such as forces, materials, and energy.

Science skills: working scientifically

Practical investigation is central to scientific activity of all kinds. What distinguishes a scientific activity from other forms of enquiry is not the sophistication of the ideas used but the process through which these ideas are developed. A scientific approach is a process of making observations, hypothesising, predicting and carrying out investigations, planning fair tests and analysing the results of tests and investigations.

Experience of the physical world is crucial to children's cognitive development. For most children, objects and events have to be experienced in reality before they can be the subject of thought and mental manipulation. First-hand investigation is central to the way in which young children learn science. It equips them with the realisation that they can provide their own answers to problems and that they can learn from their interaction with things around them.

Activities in science will often be technological in character, because they will involve the pupils in exploring, planning, making and evaluating objects

The constructivist view of learning involves

- beginning from children's ideas and practical experiences
- reflecting on where children are in the progression towards the development of more scientific ideas
- providing opportunities for children's ideas to be tested
- assessing the extent of any change in ideas and in the skills of working scientifically.

Science and technology can make a vital contribution to the holistic development and education of the child by providing opportunities for the development of

- a broad and balanced understanding of the properties and interactions of the physical universe
- scientific ways of investigating and exploring the world
- positive attitudes to science and an appreciation of the contribution of science and technology to society.

that have a practical purpose. The topics suggested in the strands of the science curriculum provide the context both for investigative work and for designing and making tasks.

Children's learning in science

The scientific activity of children is similar to that of the scientist. Children begin from their ideas about how things are, and they change and develop these ideas by testing them in practical investigations. During their scientific activities children should be provided with opportunities to try out, challenge, change or replace ideas. This view of learning involves children developing and constructing more scientific understanding through their own ideas and experience.

Children in primary schools construct scientific ideas and concepts based on available evidence. These ideas and concepts will be refined as the children work in more demanding contexts and develop more open-ended investigative approaches to solving problems.

Science in a child-centred curriculum

A broad and balanced scientific education is concerned both with the transmission of a body of scientific theories and knowledge and with the provision of opportunities for children to work scientifically and to experience something of the way in which scientists investigate the world. As well as helping children to become scientifically literate members of society, the curriculum aims to foster positive attitudes to science and to encourage pupils to develop an appreciation of the contribution of science and technology to society.

An experimental and investigatory approach to science in the primary school can make a unique and vital contribution to the holistic development and education of the child. The science curriculum therefore provides opportunities for the child to develop a broad and balanced understanding of the properties and interactions of the physical universe through the study of a range of topics, while at the same time developing and using scientific ways of investigating and exploring the world.

The introduction, aims and broad objectives for science on p. 5–8 of the curriculum provide more specific details on the nature of the subject and on how its role may best be realised in the primary school. However, these aspirations cannot be achieved in isolation. While science plays a complementary role to history and geography within SESE, it makes its own distinctive contribution to the wider child-centred curriculum.

*Observing is a
fundamental
skill in science*

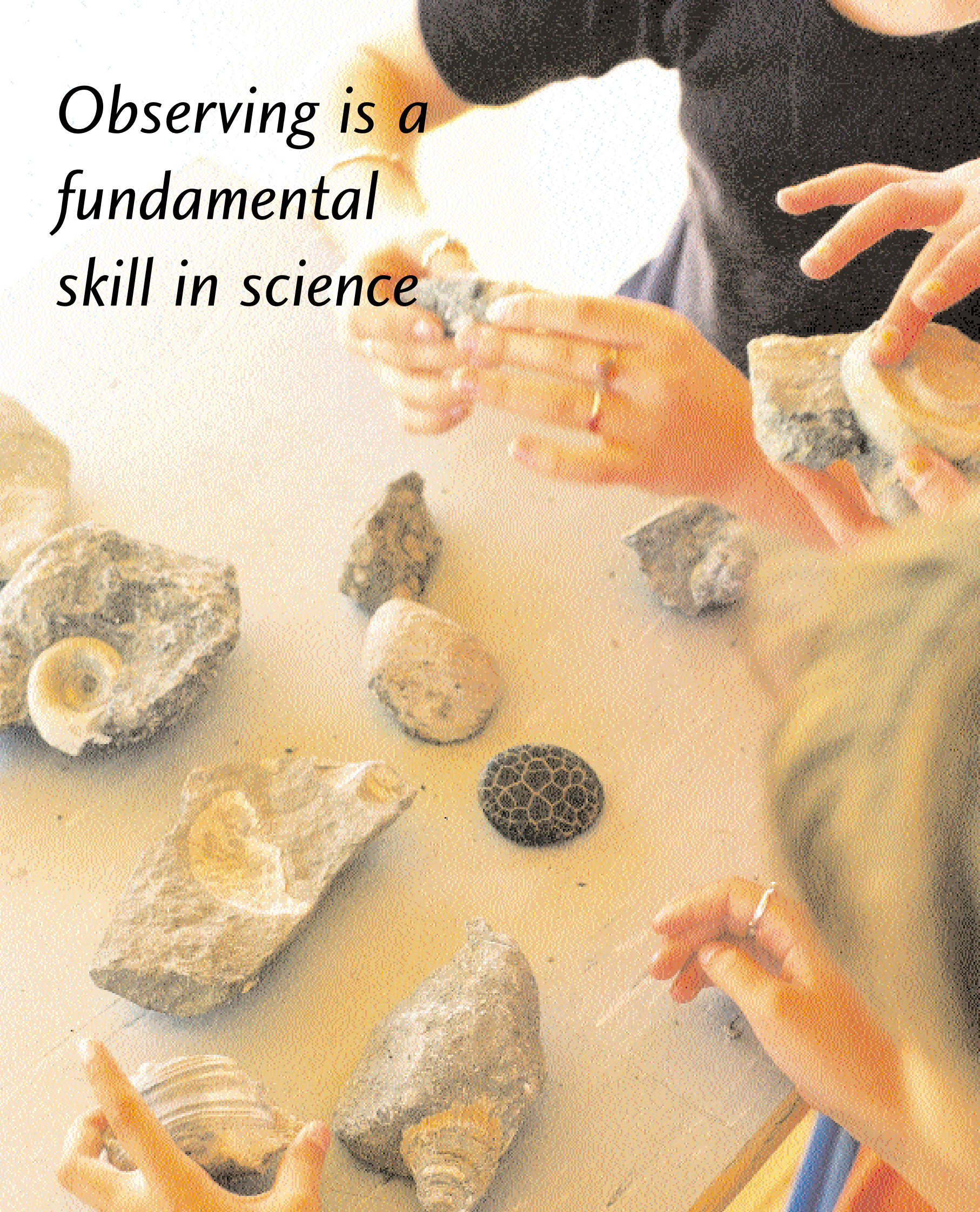

The content of the science curriculum

The content of the science curriculum

Technology in the curriculum

The technology component of the science curriculum is outlined for each level in the *Designing and making* skills section. Opportunities for technological activities are identified in each of the four content strands.

Basic structure and terminology

The content of the science curriculum has been divided into four levels: infant classes, first and second classes, third and fourth classes, and fifth and sixth classes. At each level the content has been divided into **two** distinct sections:

- **content strands**, which outline the subject matter that may be included in the science programme:

Living things

Energy and forces

Materials

Environmental awareness and care

- a **skills section**, which covers:

Working scientifically

Designing and making.

Each strand includes several topics called **strand units** that will form the basic sections of the content to be covered.

The presentation of content in these two sections is intended to help teachers in planning for the development of important skills as knowledge and understanding of scientific concepts and ideas are acquired.

Content strands

Presentation of content

The concepts and knowledge to be explored by the child are outlined in four **content strands** of the science curriculum. It is through the study of these areas of content that the scientific and technological skills described in *Working scientifically* and *Designing and making* will be developed.

How are the strands arranged?

The strands outline broad areas of knowledge and understanding, which aim to provide pupils with a framework of scientific ideas. The four areas of understanding have been chosen because they concern children's immediate everyday experiences and reflect the major areas of scientific investigation:

- Living things
- Energy and forces
- Materials
- Environmental awareness and care.

A menu curriculum

Four strands have been chosen for each class level. The organisation of these strands is designed to ensure that children experience a broad and balanced range of topics. An equal emphasis is placed on the study of living things, forces and energy, materials and environmental awareness and care at each level. It is not expected that children would cover each objective within each strand unit. The strands provide a menu from which teachers and schools can select topics that best reflect the aims and objectives of the curriculum and that enable the pupils to apply and develop their scientific skills and understandings in a broad range of contexts. It should also be remembered that the strands are not completely separate sections. Work from the strand *Living things* might include a study of an ecosystem and form an important link to *Environmental awareness and care*.

Science and geography

Many of the strands and strand units of the geography and science curricula have been planned so that the scientific skills of investigation can be developed as children study aspects of the natural environment in both scientific and geographical contexts.

The strand *Natural environments* in the geography curriculum involves the children in the study of the local natural environment and includes specific investigations of topics such as *water, air, rocks and soils, weather, climate and atmosphere* and *planet Earth in space*. These topics are of equal relevance and importance for a broad and balanced understanding of science. To avoid repetition and overlapping, these strand units have not been detailed in the science curriculum. However, it should be remembered that an exploration of environments will involve the pupils in studying content from different strand units in the geography and science curricula.

Content strands and strand units in the science curriculum

Strand	Infant classes	First and second classes
	Strand units	Strand units
Living things	<ul style="list-style-type: none"> •Myself •Plants and animals 	<ul style="list-style-type: none"> •Myself •Plants and animals
Energy and forces	<ul style="list-style-type: none"> •Light •Sound •Heat •Magnetism and electricity •Forces 	<ul style="list-style-type: none"> •Light •Sound •Heat •Magnetism and electricity •Forces
Materials	<ul style="list-style-type: none"> •Properties and characteristics of materials •Materials and change 	<ul style="list-style-type: none"> •Properties and characteristics of materials •Materials and change
Environmental awareness and care	<ul style="list-style-type: none"> •Caring for myself and my locality 	<ul style="list-style-type: none"> •Caring for myself and my locality

Strand	Third and fourth classes	Fifth and sixth classes
	Strand units	Strand units
Living things	<ul style="list-style-type: none"> •Human life •Plants and animals 	<ul style="list-style-type: none"> •Human life •Plants and animals
Energy and forces	<ul style="list-style-type: none"> •Light •Sound •Heat •Magnetism and electricity •Forces 	<ul style="list-style-type: none"> •Light •Sound •Heat •Magnetism and electricity •Forces
Materials	<ul style="list-style-type: none"> •Properties and characteristics of materials •Materials and change 	<ul style="list-style-type: none"> •Properties and characteristics of materials •Materials and change
Environmental awareness and care	<ul style="list-style-type: none"> •Environmental awareness •Science and the environment •Caring for the environment 	<ul style="list-style-type: none"> •Environmental awareness •Science and the environment •Caring for the environment

Strand: Living things

Strand units:

Myself

- Variety and characteristics of humans
- Human life processes

Plants and animals

- Variety and characteristics of living things
- Processes of life.

Children will recognise different groups of living things, such as

- birds
- farm animals
- pets
- mammals
- trees
- flowers
- insects.

Living things

This strand absorbs the existing nature study programme, which focuses on plant and animal life. It provides an excellent base on which to build and incorporate a scientific approach to the study of living things. Major themes within this strand include:

- the wide variety of living organisms (animals and plants) in the local and global environments
- the life processes, including nutrition, movement, growth and reproduction, common to animals, including humans
- the structure and function of the principal parts of the human body as they relate to some of these life processes
- the life processes, including growth, nutrition and reproduction, common to plants.

Variety and characteristics of living things

Animal and plant life

In the *infant classes* children should begin to observe and identify a wide variety of living things. Common local plants and animals should be observed and identified in the immediate environment of the school. Similarities and differences among living things should be noted, and pupils will be encouraged to recognise different groups of living things, for example birds, farm animals and pets. In *first and second classes* children should be able to identify, using common names, a range of birds, mammals, trees, flowers and insects that they have observed directly in a variety of habitats. They should become more aware of the differences between plants and animals and should begin to recognise living and non-living things in the environment. The concept of life cycle will become more familiar to children at this stage.

In *third and fourth classes* children should sort and group animals according to observable features, and they will begin to use charts, posters, videos and simple keys to aid their identification. In the *middle and senior classes* children should recognise that animals of the same species vary from individual to individual. For example, humans all belong to the same species, but we look very different from each other. They should also investigate variation in behaviour from one individual to another.

'The processes of life' is a general term that refers to the common characteristics of living things.

Human life

This strand unit aims to help children to become aware of a range of similarities and differences between themselves. While children should observe different physical characteristics, the emphasis of the activity should be on the similarities between people. Children should be encouraged to appreciate that each person is individual and unique.

The identification of the parts of the human body is included at each level of the primary programme. The overlap in suggestions within the strand units is designed to facilitate a spiral approach to the curriculum. Good planning will ensure that repetition is avoided. In this way a much more detailed study of the human body and the different life processes can be undertaken in the *middle* and *senior classes*.

The processes of life

Plants and animals

Living plants and animals have the following properties or characteristics in common: they can move, respond to stimuli, feed, respire, grow, excrete, and reproduce.

In the *infant classes* children will have little understanding of what constitutes a living organism. Through first-hand observations and experiences, such as planting seeds and bulbs and observing plants and animals in the immediate environment, children should recognise that living things grow and change. In the *junior classes* children are presented

with activities that will encourage them to develop the concept of life cycle, change and growth. In the *middle* and *senior classes* children will be aware that living things share similar life processes but that they carry out these life processes in different ways.

The processes of life—humans

In the *infant classes* and in *junior classes* children will observe and measure their physical growth and development. Through their study of *Materials* and aspects of the social, personal and health education (SPHE) programme they will begin to recognise that human beings must have certain types of food for growth and energy.

In the *middle classes* children will be helped to develop their ideas about the human body, growth, movement and breathing. Activities are presented in which children investigate their breathing rate and relate this to body processes. They can observe their own movements and come to an understanding of the different muscle systems, bones and joints in the human body. The development of children's ideas about body changes and reproduction should be in accordance with the school's policy on SPHE.

Strand: Energy and forces

Strand units:

- Light
- Sound
- Heat
- Magnetism and electricity
- Forces.

By the end of *sixth class* children should have developed a simple understanding of the basic life processes of growth, feeding, breathing, excretion, reproduction, movement, and sensitivity to the environment. They will recognise that in the human body each main life process is linked to a system of body organs.

It is not intended that children in the *senior classes* will understand cell structure or study the digestive, excretory or respiratory systems in detail. Excessive information should be avoided. There is no requirement for pupils to name the muscles or to be familiar with the scientific names for bones, all of which is more appropriate for work at post-primary level.

Energy and forces

Energy

This strand aims to help pupils understand the idea of energy, its properties and uses. Children should be able to identify everyday forms of energy, such as light, sound, heat and electricity. The safety aspects of working with different forms of energy are emphasised.

The titles of the strand units are identical for each class level. This does not mean that children at different levels will repeat work. Rather, it is to provide flexibility for the school in planning. It is not intended that all the objectives in the strand units will be taught in each class. Some objectives will be treated during *junior infants*, some will be taught in *senior infants*, while others may be profitably taught in both classes, with the more complex details, concepts and methods of investigation reserved for the *senior infants* class.

The content objectives and exemplar materials (in italic type) suggest more complex and demanding work for the *senior classes*. This can be observed by comparing and contrasting the strand units for the *middle* and *senior classes* reproduced on the following page, for example.

Strand: Energy and forces

third and fourth classes

Strand unit

Content

Light

The child should be enabled to

- learn that light is a form of energy
- recognise that light comes from different natural and artificial sources
- investigate that light is made up of many different colours
use prism to create spectrum
- investigate the relationships between light and materials
sort materials according to the degree to which they allow light through (i.e. transparent, translucent, opaque)
explore materials that do not allow light to pass through (opaque) and thus form shadows
design and make a light shade for bedroom
- investigate how mirrors and other shiny surfaces are good reflectors of light
effects of flat shiny surface, curved shiny surface
- recognise that the sun gives us heat and light, without which people and animals could not survive
- be aware of the dangers of looking directly at the sun.

Strand: Energy and forces

fifth and sixth classes

Strand unit

Content

Light

The child should be enabled to

- learn that light is a form of energy
- know that light travels from a source
- investigate the splitting and mixing of light
use prism to create spectrum
mix coloured light using filters
- investigate the relationship between materials and light (refraction)
explore how water, glass and plastic bend light
- investigate how mirrors and other shiny surfaces are good reflectors of light
effects of flat shiny surface, curved shiny surface
design and make model periscopes
- explore how objects may be magnified using simple lens or magnifier
investigate use of lens
design and make model telescopes
- understand how the eye works
- understand the role of sunlight in photosynthesis and appreciate that the sun gives us heat and light, without which people and animals could not survive
- be aware of the dangers of excessive sunlight
dangers of looking directly at the sun
effect of the sun's rays on skin
design and make a sun canopy or umbrella for toys such as dolls and models.

Strand units from the programme for third and fourth (top) and for fifth and sixth classes (above). The exemplars (in italic type) indicate that a greater range of investigative skills and depth of treatment should be expected in the senior classes.

Forces

In *infant classes* and in *junior classes* children will develop an understanding of forces and their effects through practical experiences, which will involve pushing and pulling, floating and sinking. Structured play will develop children's understanding that moving toys involves a push or a pull. They will also investigate how a force (a push or a pull) can make an object move faster, slow down a moving object, make it stop or change its direction.

Slowing down a moving object will involve the children in activities that explore friction as a force. They will establish that by increasing friction they can slow down moving objects. Reducing friction enables moving objects to move faster and further before stopping. In the *middle* and *senior classes* pupils will investigate devices such as brakes that use friction to work. At first they will investigate friction that involves solid surfaces. Later they will become aware that friction exists between a moving solid and a liquid (a boat and the water in which it is moving) and between a solid and a gas (air resistance).

A feature of the work in both the *middle* and *senior classes* is that pupils will investigate falling objects. They will discover that objects fall because of the force of gravity. They will measure force by constructing their own spring balances. By the end of *sixth class* some children may recognise that the amount of pull or force is measured in newtons.

In the *infant* and *junior classes*, children will develop their ideas about why some things float and others sink in water. Children in *junior* and in *middle classes* should discover through their practical investigations that buoyancy depends on a combination of factors, such as the material the object is made of, its shape, and the liquid in which it is placed. Children will discover that a material that normally sinks can be made to float by forming it into a hollow shape.

There is no effort at this stage to provide children with an understanding of the concept of density. Some children may develop their own ideas that an object floats if it is lighter or less dense than an identical amount (volume) of water and sinks if it is more dense. However, work on the density of different liquids and displacement will be more appropriate to the post-primary curriculum.

Materials include

- metals
- plastics
- fibres
- textiles
- ceramics
- rubber
- wood
- glass
- rocks
- water
- air.

Materials

In *infant* and in *junior classes* children should be introduced to, and be able to recognise, common materials in the immediate environment, such as food, metal, rocks, plastic, glass, wood, paper and textiles. Pupils should become aware that each material has its own characteristics or properties. Children will realise through designing and making activities and the investigation of common materials that the properties of a material make it suitable for particular uses; for example, the transparency of glass makes it suitable for windows.

Children will group materials according to how they are used in the environment, for example materials for building or for making furniture. By *third* and *fourth classes* children will be aware that some materials occur naturally, for example wood, sand and water, while others are manufactured, for example brick, concrete and plastic.

Materials and change

In *first* and *second classes* pupils will develop an awareness of the changes that may occur to solids and liquids through heating and cooling. They will observe through their investigations that some materials change from a solid into a liquid (melting), while cooling can change a liquid to a solid (solidification). In the *middle classes* pupils may also conclude that some materials can be changed permanently by heating but in other materials the changes can be reversed by cooling.

Children in the *middle* and *senior classes* will categorise materials according to the state in which they normally exist, that is, solid, liquid, or gas. They will appreciate that solids have definite shapes and may come in different forms. In the *senior classes* children should investigate water as a material in its different states. They should also appreciate that air is composed of different gases and should become aware of some of the practical applications of different gases in everyday use. The investigation of water and air as materials should link with and support the work outlined in the geography curriculum in the strand *Natural environments*.

Environmental awareness and care

This strand encapsulates many of the attitudinal aims of the science and geography curricula. It seeks to emphasise that children's experience of science should

- lead to an informed appreciation of the environments they encounter
- develop an awareness of the interdependence of the living and non-living elements of environments
- develop an understanding and an appreciation of the positive contribution of science and technology to society
- encourage positive environmental action and a commitment to sustainable life-styles and instil in them a sense of personal and community responsibility as custodians of the Earth.

An awareness and appreciation of environments is best fostered by a thorough knowledge of their distinguishing features and characteristics. By visiting and exploring different environmental features and by recording and analysing their observations children will come to appreciate them more fully and will become sensitive to the impact that change will bring.

In the *infant* and *junior classes* the unit 'Caring for my locality' is rooted in the child's awareness of the environment, the natural features to be found there and the habitats that these provide for plants and animals. The unit also encourages the identification of simple yet important opportunities for individual and group action to care for the immediate surroundings, for example in keeping the classroom tidy, in keeping the school and yard clean, and in caring for plants and animals.

In the *middle* and *senior classes* the strand unit 'Environmental awareness' provides for the study of different environments in Ireland and in other parts of the world and an examination of the interdependence and systems that are found there. Children in the *middle* and *senior classes* will develop an understanding of the relationships between the plants and animals in the environment. They will study plants and animals as elements of the whole community (ecosystem), which is composed of many other species and non-living surroundings.

Children should develop a broad and balanced view of the environment. The strand unit 'Science and the environment' encourages pupils in the *middle* and *senior classes* to appreciate the ways in which science and technology have enabled people to use the Earth's resources for the social, cultural and economic benefits of humanity. Children should be provided with opportunities to become aware of the applications of science and technology in familiar contexts in the home, school, work-place and the environment.

In the *middle* and *senior classes* the strand unit 'Caring for the environment' provides opportunities for children to examine the causes of a local, national or global issue and suggest possible solutions. An important aspect of this strand is that children should be able to explore environmental issues in a critical and informed way. They should have opportunities to contribute to and participate in the resolution of these issues whenever possible.

Skills development

Learning science will help children to develop the practical skills of investigation and of designing and making. As children use and apply these skills they will learn to deal with more complex concepts and scientific knowledge. The extent to which they can develop the skills of science will depend on their age, their stage of intellectual development and the types of practical investigations that they experience.

These science skills are seldom met in isolation but are component parts of an investigative approach to science. Throughout most stages of a scientific investigation children will observe, predict, attempt to explain and communicate. The order in which these skills are presented in the curriculum document should not be interpreted as a definitive methodology for approaching investigatory and experimental work in science.

Working scientifically will involve children in

- observing
- asking questions
- predicting
- hypothesising
- investigating and experimenting
- interpreting results
- recording and communicating results.

Working scientifically

Observing

Observing (using all the senses separately or in combination) is a fundamental skill in science. In the *infant classes* questions or comments by the teacher or children can focus the pupils' attention on objects or events. This may lead to some exploratory work and to informal sorting, where materials and living things are grouped and reorganised into different categories. At all class levels children will be asked to compare and describe similarities and differences between objects. This will lead them to observing the characteristics of familiar things, such as their shape, size, colour, pattern and texture. Observing involves activities that require several of the other skills, such as classifying and communicating.

Training pupils in safe observational techniques and emphasising the need for cautious use of the senses, especially when tasting, smelling or touching, is an important aspect of this work.

Classifying

Classifying involves children in sorting what they have observed according to one or more attributes. In *infant classes* and in *first and second classes* children will recognise properties such as colour, shape and size and will be able to sort similar objects based on one property. In *third and fourth classes* children will determine their own criteria for sorting and will be able to explain why these

criteria were chosen. In *third and fourth classes* and in *fifth and sixth classes* children will group objects into sets and sub-sets. They will also use more established means for classifying, such as keys for identifying and sorting insects, birds, leaves and trees.

Recognising patterns

The ability to see patterns in objects and processes depends on the capacity to perceive links, to detect similarities and differences, and to recognise sequences. Detecting patterns involves the pupil in linking observations with ideas and possible explanations. In *infant classes* and *junior classes* children may associate falling leaves in autumn with a decrease in temperature. In the *middle* and *senior classes* children will suggest explanations and make generalisations based on observed patterns. These explanations will help them to develop their understanding of phenomena and events in the world.

Estimating and measuring

Estimating and measuring are basic skills used to obtain information during observations. The emphasis is on using appropriate ways of measuring that are suitable to the children's stage of development and to the activity being undertaken. In the *infant classes* and in *junior classes* children will compare objects and describe them as large or small, heavy or light. They will examine a range of objects and arrange them in order, for example from the smallest to the largest.

Children will measure objects using a range of non-standard units of measurement, for example cupfuls, handfuls and hand spans. In the *middle classes* they will begin to use standard units of measurement to measure length, area, time, temperature and weight. In the *middle* and *senior classes* they will select the most appropriate equipment to aid their measurements. As the activities increase in complexity, the need for more accurate measurement will be necessary. Children will use a range of measuring instruments (ruler, balances, thermometers, scales) with accuracy and will recognise the need to measure and repeat measurements during an investigation.

The skills of estimating before actual measurements are made will be encouraged at all class levels. Skill in estimation will assist children in judging the accuracy of their results.

Weight and mass

In the science curriculum document and in these guidelines no distinction is made between the terms *mass* and *weight*. The *mass* of an object is the amount of material or matter it contains; the *weight* of an object is the amount of force being exerted on it by the pull of gravity. Most children during the primary years will not have developed the ability to grasp the distinction between mass and weight, and therefore, for general classroom use, the term 'weight' is used in these guidelines.

Questioning

Asking questions is an essential part of exploring and developing an understanding of the environment. Questioning is the means by which a child forms links between previous and new experiences. It also helps children to find out the information required to make sense of the world. Children should be encouraged to ask open-ended questions. Some of these questions should form the basis for investigative work.

Making and testing hypotheses: attempting to explain

Asking questions and suggesting possible explanations of problems are central features of the scientific process. In the *middle* and *senior classes* children will be encouraged to attempt to explain or offer hypotheses. A hypothesis is an idea that can be tested. It is a supposition, based on prior experience and knowledge, that is put forward in explanation of observed facts or as the basis for formulating predictions.

Posing questions about problems encourages children to attempt to explain or to formulate hypotheses. Hypotheses or tentative explanations do not need to be correct, but they should fit the available evidence. They become the basis for further investigation. In the *middle* and *senior classes* children should be encouraged to suggest several explanations of phenomena. These explanations will enable the children to form ideas and suggest predictions that they will want to observe or test. During their tests or investigations children will then become aware of the need to revise or reject their hypotheses in the light of new evidence.

Predicting

Patterns that have been identified in observations or in investigations can form the basis for a prediction. Pupils make predictions to forecast what might happen in certain circumstances. In the *infant classes* and in *first and second classes* children's predictions will be prompted by the teacher and will arise in structured situations. In the *middle and senior classes* pupils' predictions should be based on evidence from previous experience or observations. Pupils' predictions should be linked to the testing of ideas in investigations.

Investigating and experimenting

Investigating is the systematic search for evidence that tests an idea or explanation. In *infant classes* and *junior classes* simple investigations that are structured by the teacher will help children to think about how to approach solving problems. Pupils will identify the materials required and may suggest approaches that will help carry out the investigation. Children may realise that some things have to be controlled or kept the same in an investigation, for example the amount of water added to each plant. For children in *middle* and in *senior classes* investigating and experimenting will involve them in planning and conducting fair tests of ideas and predictions. A fair investigation will involve children in the following processes:

- *identifying the problem to be investigated*: for example, Which shoes have the best grip? Where do woodlice like to live?

Designing a fair test where the most absorbent kitchen towel is being tested will involve the children in identifying

- the variable that will be changed
- the variables that will be controlled or kept the same

What will be changed?

- the type of kitchen towel tested

What will be kept the same?

- the amount of water dropped onto each towel
- the size of towel tested.
- the amount of time given to measure the water absorbed

What will be measured or compared?

- the amount of water absorbed by each towel.

- *identifying variables*—those variables that are to be changed and those that are to be measured or compared. It will be important that children realise that they must change or vary only one condition or variable at a time. Other conditions must not vary. For example, the children can investigate the relative speed at which parachutes of varying sizes descend. Two parachutes, identical in all regards except size, should be constructed. The parachutes could then be simultaneously released from the same height. **After repeated trials the children may decide whether size influences the results**
- *selecting appropriate equipment and materials for an investigation*
- *ordering of various steps of the investigation*
- *selecting the most appropriate methods of recording*
- *analysing the results of the investigation.* The pupils will refer back to the original problem and plan any further experimental work. The results of the experiment are recorded systematically, and conclusions are stated.

Identifying variables: designing a fair test

In the *middle* and *senior classes* children will begin to recognise that an investigation or test must be fair. Fair testing involves the identification of the conditions that make a difference in an experiment. Children should identify

- the variable that they will change
- the variable that will be measured or judged
- the variables that will be controlled or held constant.

In carrying out fair tests, pupils should be encouraged to ask:

What is being tested?

What will be changed?

What will be kept the same?

What will be measured or compared?

Recording and communicating

Children will record and communicate their observations and the results of their practical work through a variety of media, for example drawings, collage, written and oral reports, and through the use of information and communication technologies. Children need opportunities to report to others how they plan their investigations, how they control or change variables, the observations and measurements made, and the results of their investigations. Through this process they may refine their own thoughts and identify new problems that need to be solved.

Pupils should be given opportunities to develop an awareness of the importance of science and technology in everyday life. This understanding will arise from experiences in familiar contexts such as the home, school, workplace and the local environment.

Designing and making

An important aspect of scientific activity is encouraging children to design and make artefacts and models that will provide solutions to practical problems. Designing and making is a process that involves pupils in using and applying their scientific skills and knowledge to practical tasks. The skills that pupils might apply in the process of solving practical problems are:

- exploring
- planning
- making
- evaluating.

Exploring

Exploring should involve children in structured and unstructured play with materials, objects and models. In the *infant classes* and in *first and second classes* children will handle and manipulate materials and develop an understanding of how materials are used to make different objects and structures. They will be given opportunities to make models from Duplo, building blocks, plastic straws and other materials. Through this exploration they will come to appreciate how their models and structures can be affected technically and aesthetically by the use of different textures, colours, shapes and choice of materials. An important aspect of the work in the *infant classes* and in *first and second classes* will be discussing and realising

the need for different designs and shapes of objects.

In the *middle* and *senior classes* children should have opportunities to design and make models and structures of their own choice, using construction kits and a wide range of building materials. They should consider and discuss how to improve and adapt objects and structures. An important aspect of the work at this level will be encouraging the children to perceive the need to design something new or to adapt a built object for a new purpose. Free exploration of materials, objects and construction toys, models and kits will be an essential element of the work at all levels.

Planning

This skill involves the children in imagining, planning and designing an object that they will make. At all class levels children will be encouraged to work in groups and to share and communicate their ideas. In the *infant classes* and in *first and second classes* children may make simple drawings or models. They will be guided by the teacher in their choice of materials, tools and ways of working.

In *third and fourth classes* and in *fifth and sixth classes* children should be able to create a range of design proposals and compare and consider the merits of different designs. Through discussion they will be able to assess the feasibility of undertaking different design proposals and will review and adapt their designs to accommodate their skills, range of resources, materials and time allocated to the task. It will be important that this work will link with the development of spatial skills in mathematics and geography, and opportunities for designing and making should be identified in these curricular areas.

Making

This part of the designing and making process will involve children in making and producing the product or artefact that they have designed and planned. The development of craft-handling skills, such as cutting, joining, fastening, weaving and linking, will be essential for the construction of models and artefacts that the children will design. An important aspect of the work at all levels is that children will select and use appropriate tools. This will require careful supervision, and safety is an important skill and attitude for children to develop at each phase of the designing and making process.

In the *infant and junior classes* the range of tools will be limited to those that will have been encountered in craft activities. In the *middle and senior classes*, as a more diverse range of materials, such as wood and plastic, is introduced, children will have access to a wider range of tools. To ensure progression and continuity in designing and making tasks, children should have access to and experience working with an ever increasing range of materials and tools that will enable them to realise their design proposals.

Evaluating

Evaluating the product that has been designed and produced by the children can help them to suggest improvements to their designs and to consider ways of modifying their way of working and planning. Children should be provided with opportunities to review what other groups have produced and to see how well the resulting products match their design proposals. Children should suggest modifications to designs and, in an atmosphere of positive criticism, be encouraged to try other design proposals in an effort to provide more appropriate solutions to the problems that were identified.

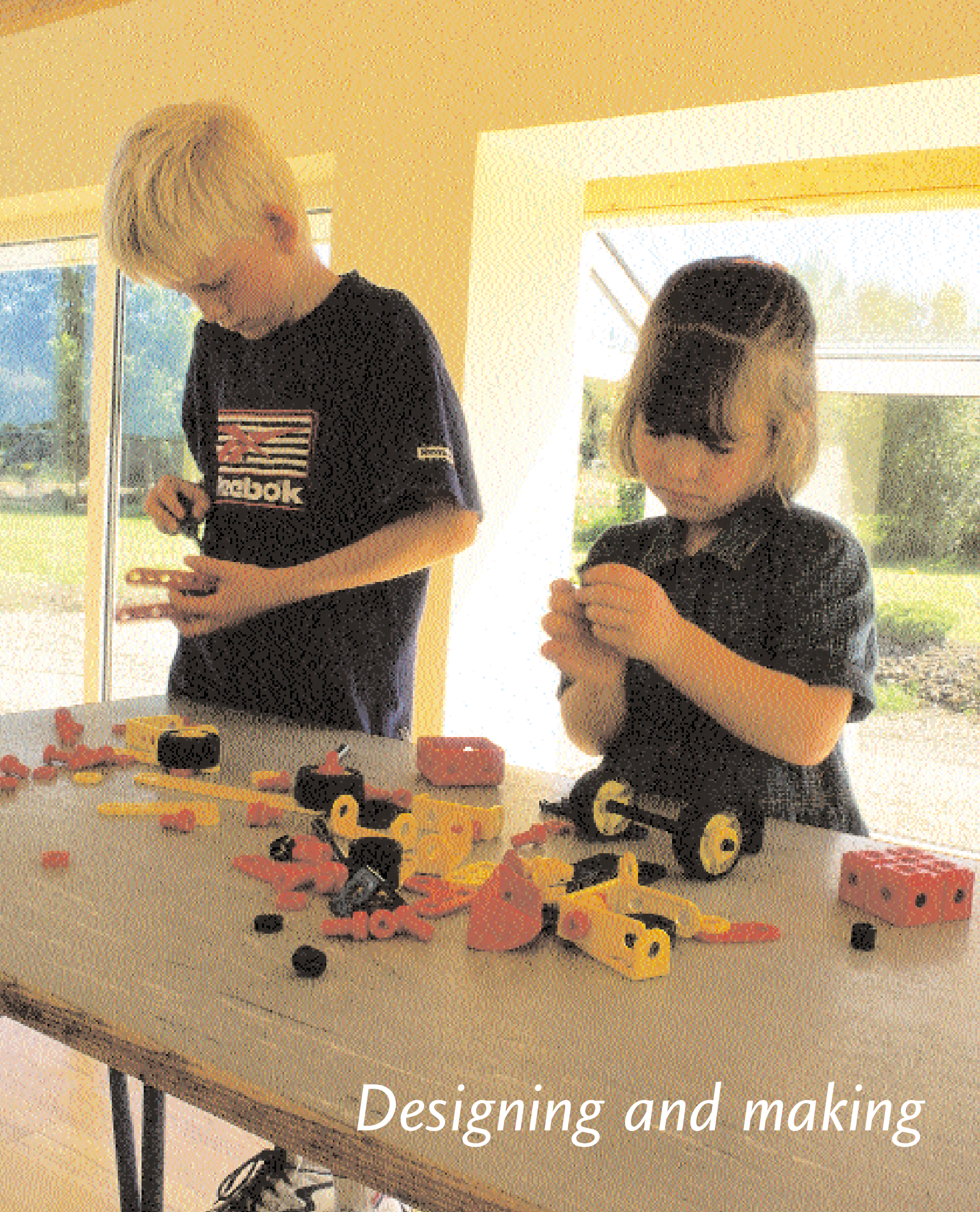

Designing and making

School planning for science

School planning for science

The successful implementation of the science curriculum will be dependent on efficient planning by the school and teachers. This section will examine two aspects of this planning process:

- curriculum planning
- organisational planning.

Curriculum planning

The issues that may need to be discussed as part of the school's planning for science include the following:

The purpose and nature of science in the school

A science programme that aims to help children to work scientifically involves the development of a broad range of skills of enquiry, the cultivation of important attitudes and the acquisition of scientific knowledge and concepts about the biological and physical aspects of the world. The science curriculum is structured so that children can experience all these elements.

A shared understanding of the purpose and nature of science will promote a co-ordinated approach to the planning and teaching of science throughout the school and will also facilitate the evaluation of teaching resources and approaches.

Balancing theme teaching and a subject-centred approach

An integrated curriculum is particularly suited to younger children, because they view the world and their experiences in a holistic way. Many schools may choose to adopt a thematic approach to their organisation of work in SESE for infant and junior classes.

As children grow older, appropriate teaching strategies can vary; they may include a holistic or theme-based approach, some cross-curricular integration and a subject-centred focus. Theme teaching and the use of subject integration will remain important at all levels, but these approaches rely on careful planning by the staff to ensure that the role and distinctive contribution of each subject are realised. In particular, planning should help to ensure that, within the range of themes used, a broad and comprehensive coverage of the content strands is achieved and that adequate opportunities are provided for the development of scientific skills and concepts.

The exploration of the school and the locality will involve teachers in becoming familiar with

- the range of habitats in the area
- the features of the natural environment
- the materials from which the school is built, for example wood, plastic, slate, steel, glass, brick
- the direction in which the school is facing.

The exploration of the school and the locality

One of the most important aspects of the science curriculum and the wider SESE programme is the emphasis placed on the exploration of the local environment of the child and school. The planning process should involve teachers in becoming familiar with the locality of the school, the range of habitats in the area and other features of the natural environment. Familiarity with the locality should facilitate the selection of topics for inclusion in the science programme.

Schools differ considerably in the facilities available to them. As part of the planning process some schools may set up a bird table or weather station or lay out a school garden, all of which will provide opportunities for work throughout the different strands.

Textbooks and workcards

Textbooks and workcards can be used during science lessons to support active investigative work. These resources should be discussed and evaluated by the staff as part of their school plan for science. It will be important to select a range of secondary sources that will help to support children as they work scientifically and as they undertake designing and making tasks. Science lessons **should not be workcard or textbook based**. Rather teachers should select activities from a variety of textbooks and workcards that will assist children in undertaking open-ended tasks.

Safety in science activities

During practical work teachers should be aware of the safety implications of any exploratory or investigative work to be undertaken. Primary science activities should not involve the use of chemicals or other hazardous materials. However, safety should permeate all aspects of the teaching of science, and children should be encouraged to observe safety procedures during all tasks. Safety precautions cannot remove all risks but should eliminate unnecessary hazards. Useful safety advice is provided in *Safety in School Science* (Dublin, An Roinn Oideachais, 1996).

The main features in the progression of children's scientific ideas are:

- they gradually become more abstract—knowing that light rays travel in straight lines is an abstract idea because it is not easily perceived
- they become more complex—they concern how things happen: for example, looking through lenses can change the appearance of objects
- they can be transferred to unfamiliar situations
- they become more precise.

A broad and balanced science curriculum

Planning should help teachers to ensure that the science programme

- includes a broad range of topics from each of the strands. The science programme should be sufficiently broad to ensure that children have access to a comprehensive range of scientific concepts
- provides opportunities for children to work scientifically. It is essential in planning for science at each level that working scientifically will form an essential part of the approach
- achieves a balance between the different aspects of the curriculum. There should be a balance between the strands and strand units of the curriculum. Each year children should experience topics from each strand unit. *It is intended that over a two-year period all strand units from each strand should be covered.* There should also be a balance between the development of scientific knowledge and understanding and the processes of working scientifically
- helps to unite science and technology. Investigations should provide opportunities for pupils to engage in activities that involve designing and making

- gives children plenty of opportunities to explore and investigate the environment
- provides for continuity and progression in the development of scientific ideas and in the application of investigative skills.

Developing an assessment policy

The assessment of children's learning is an essential and continuous part of the teaching and learning process in science, as in the other areas of learning. An important aim of the school plan for science should be to help teachers come to a shared understanding of the way in which children's progress in science can be assessed, documented and reported. Assessment of the science curriculum should facilitate teachers in evaluating the suitability of the science programme selected for a particular age group.

The assessment techniques in science must focus on knowledge objectives, understanding of scientific concepts, competence in the application of experimental and investigative skills and the cultivation of important attitudes. The curriculum recommends that the following assessment methods be used to obtain a broad and balanced picture of the child's progress in science:

- teacher observations
- concept-mapping
- teacher-designed tasks
- work samples and portfolios.

Organisational planning

Developing the school plan for science

Planning for science in the school should

- create a common understanding of the nature and role of science in the curriculum. Organisational planning for science should be a collaborative and consultative process involving the principal and teachers and, where appropriate, parents and the board of management. A written statement of the school's policy for science will be a useful record and reference point for the staff and will provide teachers with a clear sense of direction and purpose
- seek to make use of the interests and aptitudes of teaching staff and provide for the sharing of expertise and the co-ordination of teaching resources
- involve a review of the facilities and resources available to the school
- determine how the school intends to phase in the new programme
- involve review and evaluation during development and after a fixed period
- involve communication between the principal, teachers, parents and the board of management.

Supporting the implementation of the science curriculum

Some useful strategies and potential sources of support for the implementation of the SESE curriculum are outlined in the *Teacher Guidelines for SESE: History* and in the *Teacher Guidelines for SESE: Geography*. Teachers should refer to these documents to identify how existing resources can best be used to support the implementation of the science programme and to identify where further help is required.

The contribution of parents and local people

The emphasis that the science curriculum places on the exploration of the environment will mean that the children's families may help to enrich and support the programme in many ways. Parents and local people may contribute to such science activities by

- sharing knowledge and expertise
- helping to organise visits to places of interest, such as farms, factories, museums and science centres
- working with small groups of children.

Section 4

Classroom planning for science

Classroom planning for science

This section gives advice on the planning of the teacher's work. It deals with

- the teacher's planning
- planning a unit of work
- integrated learning.

The teacher's planning

Much of the advice given in the previous section is also relevant to planning by individual teachers. In addition, consideration should be given to the following:

The learning experiences and needs of the children

The learning experiences of the class, the scientific concepts and investigations completed by the children so far and the development of individual pupils' scientific ideas will be the starting point for the teacher's planning in science. Liaison with the previous class teacher and the review of class records will provide the teacher with useful information when drawing up a new programme and planning schemes of work.

The school's programme for science

The content of the strands and strand units in the curriculum statement and the sections that describe the development of skills, 'Working scientifically' and 'Designing and making', provide the basis for the teacher's work with the class. The school plan for science will provide further direction for the teacher's work with the class.

Planning and selecting content

Planning and selecting units of work for science in the school will ensure that the children experience a broad and balanced programme. The scheme of work in *Exemplar 1 for junior classes* illustrates how a programme for science for this level may be planned to ensure that children have access to scientific concepts from each of the strands. The exemplar shows how provision may be made for children to study units of work from **each** of the strands during **each** term. It should be noted that some of the units chosen by the teacher may incorporate elements from more than one strand. For example, a unit of work on trees in the local environment will also include investigations of wood as a material as well as a consideration of strategies for protecting natural features in the environment. The main focus for each unit of work is presented in **bold type**.

Planning for the development of skills and concepts

The teacher's scheme of work should focus on both concepts and skills.

Learning activities should

- be based on children's existing ideas, help to test predictions based on these ideas and change ideas to better fit the evidence
- arouse curiosity and stimulate exploration and investigation
- optimise opportunities for the children to interact with materials and a range of ideas from other children, from adults and from a variety of secondary sources, such as books, videos and other media
- help children to test their ideas and predictions through investigating and designing and making.

Approaches and methodologies

The use of a range of teaching methods and approaches is essential when teaching science. An effective science programme should encourage children to ask questions, test their ideas and observe and explore the natural and physical world. Suggestions for a range of methodologies that are appropriate to the teaching of science topics are given on pages 52 to 145.

Seasonal factors

Many opportunities should be provided for the children to observe and interact with their environment. Children should work outdoors regularly to observe the effects of seasonal change, to investigate materials and to explore animals and plants in a variety of habitats. Planning for work outdoors should be sufficiently flexible to allow for adverse weather.

The availability of resources and support

It is helpful to establish the resources and support that might be available to plan and implement units of work. Consideration should be given to inviting parent volunteers to assist with certain activities, for example work in the outdoors and small-group work. Appropriate in-service courses should be identified that would provide guidance on the implementation of a strand or strand unit. Staff members should be encouraged to share their knowledge and their expertise in applying different approaches and methodologies.

During this phase, teachers may identify a range of secondary sources, such as books, videos, CD-ROMs and other media that may be used by the children as sources of background knowledge and provide ideas for scientific investigations.

Exemplar 1

A possible programme of work for junior classes incorporating units from each strand

		Living things	Materials	Energy and forces	Environmental awareness and care
Year 1 Autumn term	Unit 1	Trees in the park	Wood		Caring for the local area
	Unit 2		Houses and homes		
	Unit 3	My senses—ears and hearing		Sound	
	Unit 4	My senses—eyes and seeing		Light	
Winter-spring term	Unit 1	Growing and changing			
	Unit 2	The farm			Caring for plants and animals
	Unit 3		Materials and change		
	Unit 4			Magnetism	
Summer term	Unit 1			Floating and sinking	
	Unit 2	The pond			Caring for plants and animals
	Unit 3				The school garden
	Unit 4		Wet and dry		
Year 2 Autumn term	Unit 1			Heat	
	Unit 2	Seasonal change in living things			Caring for living things
	Unit 3		Clothes		
	Unit 4	Myself			
Winter-spring term	Unit 1				Caring for a local habitat
	Unit 2	Growing seeds and plants			
	Unit 3			Electricity	
	Unit 4		Mixing different materials		
Summer term	Unit 1	Animals and plants near my school			
	Unit 2		Toys	Pushing and pulling	
	Unit 3				Litter
	Unit 4		Materials in my classroom		

Providing for individual differences

Providing for a broad and differentiated curriculum is necessary to fulfil the social and learning needs of individual pupils. Activities should be planned that are appropriate to the children's levels of ability and experience. Teachers should consider

- using a combination of whole-class teaching and focused group work
- planning topics that provide opportunities for further investigative work for the more able or less able
- planning units of work that are based in familiar contexts
- starting with the child, his/her ideas and level of understanding
- providing opportunities for interacting and working with other children in small groups
- allowing children to work with concrete materials
- inviting parents and other support people to work with mixed-ability groups to assist the more able or less able child
- using investigations as the basis for practical work. Children respond differently to open-ended tasks according to their existing knowledge and understanding. Open investigations provide opportunities for children to pursue their solutions to problems.

Assessment

Assessment of pupils' progress is an important aspect of the cycle of planning, teaching, learning, assessment and evaluation. Continuous formative assessment is part of the teaching and learning process, and it will provide the teacher with information that can be used to assess whether the objectives of an investigation have been met by the children. The information obtained from the teachers' observations and from teacher-designed tests and tasks can help with the teacher's planning of experiences that match the children's achievement and will help children's progress.

When planning units of work the teacher should

- be aware of the children's past learning experiences
- select from the strands and strand units outlined in the curriculum and in the school plan for science
- clarify and identify the detailed content that is to be covered in the unit of work
- identify the learning outcomes to be achieved
- specify the methods of assessment
- outline the science activities that the children will undertake
- consider the teaching approaches that can be employed
- provide for individual differences
- identify the resources required for the topic and the equipment in the school
- plan for the communication and recording of work and findings.

Planning a unit of work

Systematic planning by the teacher will be crucial for the success of the science programme. Such planning should cover the acquisition of knowledge, the development of skills and attitudes and the use of appropriate assessment. In planning units of work, the teacher should

- *be aware of the children's past learning experiences.* Consulting the former class teacher and reviewing the pupil profile cards and class records will provide the teacher with information about the scientific work completed and the progress children have made in working scientifically and designing and making
- *select from the strands and strand units outlined in the school plan for science and in the curriculum.* The topics should take account of the needs and aptitudes of the pupils, reflect the local environment and ensure continuity and progression in children's learning
- *clarify and identify the detailed content that is to be covered in the unit of work.* This will specify the scientific knowledge and concepts that children will develop through their science work
- *identify the learning outcomes to be achieved.* This will provide the basis for the assessment of pupils' learning and progress
- *specify the methods of assessment to be used*
- *outline the science activities that the children will undertake.* The plan of work should also incorporate the many continuing activities that children may experience daily or weekly, such as recording the weather, taking care of animals and plants in the classroom or working with the sand or water tray. Teachers should plan some activities that small groups of children can undertake without adult supervision. Investigation tables may also be set up in the classroom with associated questions on cards. These experiences need to be planned carefully to ensure that all pupils have equal access to the activities
- *consider the teaching approaches that can be employed.* Using a range of teaching approaches and methodologies will ensure the balanced development of knowledge and skills and the engagement of all pupils in active investigations

- *provide for individual differences.* Teachers should plan activities that all children should complete as well as providing support activities for the less able child or more able child. Consideration should also be given to organising the children in groups and the extra help and tuition that some children may require during the learning activities
- *identify the resources required for the topic and the equipment in the school.* The sharing of resources among teachers in the same school or in a cluster of schools needs to be carefully managed so that the use of specialised equipment, such as thermometers, nature viewers, magnets, bulbs and batteries, can be maximised
- *plan for the communication and recording of work and findings.* The communication of children's ideas is an essential part of working scientifically and designing and making. Consideration should be given to providing opportunities for children in other classes in the school, for parents and other interested members of the school community to view the results of the children's work.

Some planning exemplars

The exemplars that follow show how a number of strand units can be presented so as to produce a plan for teaching, learning and assessment. Each exemplar shows

- the relevant strand unit from the curriculum
- the skills for the class level outlined in the section 'Working scientifically'
- the development of the unit by the teacher
- methodologies
- assessment techniques.

The sample units include

- a unit for *infant classes* based on forces
- a unit of work on forces for the *senior classes*. *Exemplar 3A* illustrates how the curriculum objectives may be achieved by pupils in fifth class. *Exemplar 3B* outlines how the topic may be developed for pupils in sixth class
- a unit of work for *third and fourth classes* based on the topic of magnetism
- a unit of work for *fifth and sixth classes* based on the topic of electricity.

Exemplar 2

A unit of work based on forces

infant classes

Strand unit from the curriculum	Development of the unit	Working scientifically
<p>The children should be enabled to</p> <ul style="list-style-type: none"> • explore, through informal activity with toys, forces such as pushing and pulling • explore how the shape of objects can be changed by squashing, pulling and other forces • investigate how forces act on objects <i>group objects that will sink or float.</i> 	<p>The children should learn that</p> <ul style="list-style-type: none"> • a push is needed to make things move • a pull can also make things move • pushes and pulls can speed up or stop a moving object (although a barrier is the most effective way of stopping something) • squashing, squeezing, stretching and twisting involve pushes and pulls and can change the shape of an object, e.g. squeezing a sponge or squashing a can • some things float and some things sink in water • the material from which an object is made is important and affects buoyancy • objects can be grouped into floaters and sinkers • some things float high in the water. 	<p>Children should be enabled to</p> <p>observe observe characteristics of objects to be tested</p> <ul style="list-style-type: none"> • it is made of wood/metal/plastic • it is big, small, light, heavy • it is squashy, stretchy <p>question ask questions such as</p> <ul style="list-style-type: none"> • What happens when you put x or y in the water? • Does all wood float? • What makes a thing move? <p>predict guess what will happen</p> <ul style="list-style-type: none"> • I think it will float/sink • I think it will go faster <p>sort and classify sort and group objects</p> <ul style="list-style-type: none"> • sets of objects that float/sink • set of things that can be squashed <p>investigate and experiment carry out simple investigations on floating and sinking</p> <ul style="list-style-type: none"> • test which objects float and sink in water • investigate ways of moving a large, heavy box
<p>Methodologies</p>	<p>Assessment</p>	
<p>Among the methods and teaching approaches that may be used are:</p> <ul style="list-style-type: none"> • discovery learning • teacher-guided learning. 	<p>Among the techniques that may be used are:</p> <ul style="list-style-type: none"> • teacher observation <i>outcomes of pupil-pupil and teacher-pupil discussions</i> • teacher-designed tasks <i>pictures or diagrams of ideas</i> • portfolio assessment <i>samples of recording and communication completed by pupils</i> • concept-mapping <i>maps of children's ideas about forces, levers and friction.</i> 	<p>estimate and measure describe weight and length</p> <ul style="list-style-type: none"> • this object is heavier/lighter than the last one we tested • when I gave it a big push it went as far as the door <p>record and communicate record findings pictorially</p> <ul style="list-style-type: none"> • charts or posters of things that sink/float <p>describe observations orally</p> <ul style="list-style-type: none"> • to make the table move you push it/pull it.



In the infant and junior classes children will develop ideas about why some things float and others sink in water.

Exemplar 3A

A unit of work based on forces

fifth class

Strand unit from the curriculum	Development of the unit	Working scientifically
<p>The children should be enabled to</p> <ul style="list-style-type: none"> identify and explore how objects and materials may be moved <i>by pushing and pulling by machines using rollers, wheels, axles, gear wheels, chains and belts</i> explore the effects of friction on movement and how it may be used to slow or stop moving objects <i>a bicycle wheel by a brake</i> explore how friction can generate heat <i>rubbing hands</i> explore how levers may be used to help move different objects <i>design and make a toy using a lever design and make a lifting device that uses levers and gears.</i> 	<p>Children should learn that</p> <ul style="list-style-type: none"> forces are needed for movement forces can be thought of as pushes and pulls machines make it easier to use forces rollers, wheels and axles make it easier to move heavy things gear wheels are used to turn other wheels. They transfer forces, for example from the pedals to the wheels of a bicycle some machines have wheels joined by a belt or chain. This belt is used to make the wheels move friction makes it difficult for objects to move against each other: it can make moving objects slow down and stop the brakes on a bicycle wheel are pads of rubber. When you use the brake handles the pads press against the wheel and stop it from turning rubbing your hands together quickly makes them warmer. Friction causes heat as rough surfaces rub together we use levers in many different ways levers make work easier a pop-up figure in a book is worked by a lever. 	<p>Children should be enabled to</p> <p>observe</p> <ul style="list-style-type: none"> notice the effect of forces on a variety of materials, for example magnetic force on metals, frictional force on wood, stone and skin <p>question</p> <ul style="list-style-type: none"> How many machines can you see in the classroom? Can air be used to lift things? <p>predict</p> <ul style="list-style-type: none"> I think a steeper slope will make an object roll further If the pedal is pushed round once the back wheel will go round three times Sandpaper on the slope will slow the car down <p>classify</p> <ul style="list-style-type: none"> sort machines in different groups <p>investigate</p> <ul style="list-style-type: none"> devise a test to find out if one rubber band has more power than another. Test what difference thickness or length makes <p>analyse</p> <ul style="list-style-type: none"> conclude that everything that is rubbed seems to get hot, for example car tyres after a journey, shoe soles that have been used as a brake
<p>Methodologies</p>	<p>Assessment</p>	<p>interpret</p>
<p>Among the methods and teaching approaches that may be used are:</p> <ul style="list-style-type: none"> exploration with different construction materials (e.g. Duplo, Lego) discovery-learning teacher-guided learning. 	<p>Among the techniques that may be used are:</p> <ul style="list-style-type: none"> teacher observation <i>outcomes of pupil-pupil and teacher-pupil discussions</i> teacher-designed tasks <i>pictures or diagrams of ideas</i> portfolio assessment <i>samples of recording and communication completed by pupils</i> concept-mapping <i>maps of children's ideas about forces, levers and friction.</i> 	<p>evaluate</p> <ul style="list-style-type: none"> it might be easier to study seesaws and to make measurements by using a ruler and two weights.

Exemplar 3B

A unit of work based on forces

sixth class

Strand unit from the curriculum	Development of the unit	Working scientifically
<p>The children should be enabled to</p> <ul style="list-style-type: none"> identify and explore how objects and materials may be moved <i>by pouring and pumping using trapped air pressure (pneumatics)</i> <i>using trapped liquid under pressure (hydraulics)</i> come to appreciate that gravity is a force become aware that objects have weight because of the pull of gravity design and make a spring balance explore the effects of friction on movement and how it may be used to slow or stop moving objects <i>a falling object by a parachute</i> <i>air resistance, streamlining.</i> 	<p>Children should learn that</p> <ul style="list-style-type: none"> air can be squashed into a small space, for example pumping air into a tyre. Compressed air gives the force to a machine to break up concrete air can be used to lift heavy objects such as books a heavy weight can be lifted using (a little) water. Excavators often use hydraulics the weight of something is a measure of how hard the Earth is pulling on it the greater the pull of gravity on something the more it weighs things are pulled towards the centre of the Earth. Objects fall because they are pulled towards the centre of the Earth. This pull is the force of gravity forces can be measured with a spring balance (also called a forcemeter): the more the spring is pulled the more it stretches. The greater the pull the more an object weighs the pull is measured in newtons any falling object must push through the air on its way to the Earth air resists being pushed away; it pushes back, creating air resistance a streamlined shape cuts through the air more easily than a flat, square shape a streamlined shape can overcome air resistance more easily than something that is not streamlined. This is important for speed and flight. 	<p>observe</p> <ul style="list-style-type: none"> dropping objects of different shapes dropping weights of different weight dropping objects of different shapes but of equal weight parachutes falling the effect of tying objects of different weights onto rubber bands <p>predict</p> <ul style="list-style-type: none"> if we drop two toys, which one will hit the ground first? which material will make the best parachute? which rubber band will stretch the most? <p>question</p> <ul style="list-style-type: none"> can you describe what happens when the feather and conker fall <p>investigate</p> <ul style="list-style-type: none"> the effects of different weights on the same parachute <p>estimate and measure</p> <ul style="list-style-type: none"> use a spring balance to measure the force of gravity i.e. weight <p>analyse</p> <ul style="list-style-type: none"> examine the relationship between the size of the parachute and the speed at which something that is attached to it falls
<p>Methodologies</p>	<p>Assessment</p>	
<p>Among the methods and teaching approaches that may be used are:</p> <ul style="list-style-type: none"> free exploration with materials used to design and make parachutes, models using gears and levers discovery learning teacher-guided learning. 	<p>Among the techniques that may be used are:</p> <ul style="list-style-type: none"> teacher observation <i>outcomes of pupil-teacher discussions</i> teacher-designed tasks <i>pictures or diagrams of ideas about forces and levers</i> portfolio assessment <i>samples of recording and communication completed by pupils</i> curriculum profile. 	

Exemplar 4

A unit of work based on magnetism

middle classes

Strand unit from the curriculum	Development of the unit	Working scientifically
<p>The child should be enabled to</p> <ul style="list-style-type: none"> • learn that magnets can push or pull magnetic materials • explore how magnets have poles and investigate how these poles attract and repel each other • explore the relationship between magnets and compasses • examine and classify objects and materials as magnetic and non-magnetic • investigate that magnets attract magnetic materials through other materials <i>magnets attracting materials through water, glass, plastic.</i> 	<p>Children should learn that</p> <ul style="list-style-type: none"> • magnets can make things move by pushing or pulling them • magnets attract objects most strongly at the ends or poles • magnets can be made from magnetic materials • magnetic materials such as iron and steel can be used to make magnets by stroking the material or object in the same direction with one pole of an existing magnet • learn that the magnet they have made can be used as a compass • the Earth acts like a giant magnet • the north-seeking pole of a magnet points towards the Earth's magnetic north pole • the south-seeking pole of a magnet points towards the Earth's magnetic south pole • magnets attract objects through some materials. 	<p>Children should be enabled to</p> <p>observe</p> <ul style="list-style-type: none"> • the parts of the magnet that are strongest or weakest • the pushing or pulling force of different magnets • the characteristics of magnetic materials • how a pin or nail can be magnetised <p>predict</p> <ul style="list-style-type: none"> • Which objects in the classroom will the magnet pull? • If we stroke a large steel nail with a magnet will we get the same results as with the pin? <p>classify</p> <ul style="list-style-type: none"> • grouping objects into magnetic and non-magnetic <p>question</p> <ul style="list-style-type: none"> • Which is the strongest part of the magnet? • What materials can we use to make a magnet? • What will happen if we stroke the needle in different directions? • Will the magnet attract all metals? <p>measure</p> <ul style="list-style-type: none"> • Are both ends of a magnet equally strong? How can we find out? Arrange magnets in order, from weakest to strongest
<p>Methodologies</p>	<p>Assessment</p>	<p>hypothesise</p> <ul style="list-style-type: none"> • What objects can be made into magnets? • How strong can we make each magnet? <p>experiment</p> <ul style="list-style-type: none"> • What are some ways to test a magnet's strength? <p>infer</p> <ul style="list-style-type: none"> • decide which objects (materials) magnets attract • there is a connection between the number of strokes used to magnetise an object and the object's magnetic strength.
<p>Among the methods and teaching approaches that may be used are:</p> <ul style="list-style-type: none"> • free exploration with magnets and a variety of materials • discovery learning <i>magnetic/non-magnetic materials; magnets attracting through other materials</i> • teacher-guided learning <i>Earth's magnetism; magnetic field.</i> 	<p>Among the techniques that may be used are</p> <ul style="list-style-type: none"> • teacher observation <i>outcomes of pupil-pupil and teacher-pupil discussions</i> • teacher-designed tasks <i>pictures or diagrams of ideas about magnets and magnetism</i> • portfolio assessment <i>collect and add to portfolio samples</i> • curriculum profile <i>use teacher observations and portfolio to complete profile at the end of term.</i> 	

Exemplar 5

A unit of work based on electricity

senior classes

Strand unit from the curriculum	Development of the unit	Working scientifically
<p>Magnetism and electricity The child should be enabled to</p> <ul style="list-style-type: none"> learn about electrical energy investigate current electricity by constructing simple circuits <i>use wire, bulbs, motors and batteries use more than one bulb in a circuit use more than one battery in a circuit experiment with simple switches design and make a set of traffic lights using a simple circuit and switch</i> <ul style="list-style-type: none"> become aware of how some common electrical appliances work become aware of and understand the dangers of electricity <i>dangers of mains electricity in the home and at work the importance of fuses and circuit-breakers for safety.</i> 	<p>Children should learn that</p> <ul style="list-style-type: none"> a complete circuit is needed before electricity can flow a battery provides the energy for the electricity to move around the circuit metals allow electricity to flow through them and can be used as switches to complete a circuit and make links between the batteries, bulbs and buzzers increasing the number of batteries used (voltage) in a circuit increases the current several batteries can be used together in a circuit. <p>Children should never conduct experiments with mains electricity. They should become aware that</p> <ul style="list-style-type: none"> mains electrical energy is generated and distributed at high voltage a circuit is formed when an appliance, such as a kettle, is connected to mains electricity by means of a socket and is switched on fuses are used as safety components in electrical circuits circuit-breakers are very sensitive to increased current and are usually built into the circuit where the mains supply comes into the house. 	<p>Children should be enabled to</p> <p>observe</p> <ul style="list-style-type: none"> add another battery to the circuit. What, if anything, happens to the light? add another bulb to the circuit. What happens to the brightness of the lights? look around the room. What objects or materials will conduct electricity? <p>predict</p> <ul style="list-style-type: none"> If the wire is disconnected at one end of the battery what will happen to the light? What will happen if we disconnect one of the wires in a series circuit? How many times brighter will the bulb be with two batteries? <p>question</p> <ul style="list-style-type: none"> How will we get a bulb to light? Can we get two bulbs to light in this circuit? Where should the switch be added? What materials can we use to make the switch? Do switches have to be made from magnetic materials? <p>measure</p> <ul style="list-style-type: none"> get some batteries of the same size. How can we compare how strong each is? Can we put them in order, from weakest to strongest? <p>infer</p> <ul style="list-style-type: none"> Why did the light get brighter? How does the electricity seem to flow in a circuit with two bulbs?
<p>Methodologies</p>	<p>Assessment</p>	
<p>Teaching approaches Among the methods that may be used are:</p> <ul style="list-style-type: none"> discovery learning <i>materials that conduct electricity; making circuits; adding buzzers and switches to circuits</i> guided discovery <i>making circuits with more than one bulb; the use of fuses in circuits</i> open-ended investigations. 	<p>Among the techniques that may be used are:</p> <ul style="list-style-type: none"> teacher observation <i>outcomes of pupil-pupil and teacher-pupil discussions</i> concept mapping teacher-designed tasks portfolio assessment <i>records of work completed by pupils</i> curriculum profile <i>use teacher observations, concept maps and portfolio to complete profile at the end of the term.</i> 	<p>experiment</p> <ul style="list-style-type: none"> How many ways can we light a bulb using wire and a battery? How many ways can we light a bulb with two wires and one battery? How many ways can we light two bulbs with three wires and only one battery? <p>investigate</p> <ul style="list-style-type: none"> How long will a torch battery light a bulb? How can we find out which materials conduct electricity? Can we make a lighting system for a toy house?

Integrated learning

Planning for linkage and integration

Integrated learning, both within subjects and between curricular areas, is an important principle of the curriculum.

Linkage could take place

- *within science*: The science curriculum is presented in four strands. Teachers will find that studies based on the strand *Living things* will give rise to the consideration of topics delineated in *Environmental awareness and care*. It is through the strand and strand units of the science curriculum that the children will be provided with opportunities for the simultaneous development of skills and knowledge.

Integration could take place

- *within SESE*: Many opportunities exist for links to be made between science and geography.

The close alignment of skills outlined in the sections 'Working scientifically' and 'Geographical investigation skills' demonstrates how the processes of science can be applied to geographical investigations. There will also be opportunities during geography for pupils to undertake *designing and making* tasks as they construct models of environmental features.

The study of *Living things* will link to and complement the topics outlined in natural environments in the geography curriculum. The units defined in this strand, which are based on weather, rocks and soil, water and astronomy, should be planned so that the content objectives can be achieved through science and geography. The strand *Environmental awareness and care* is common to the science and the geography curricula.

Integrating science with other subject areas

The links between science and other curricular areas are highlighted in the curriculum. Science has special links with SPHE, visual arts, mathematics and language. In particular:

SPHE: The objectives of the strand unit 'Myself' link with and are developed in the strand *Myself* in the SPHE curriculum

mathematics: The skills outlined in *Working scientifically* and *Designing and making* can contribute to the child's mathematical development. The problem-solving skills that children develop in mathematical contexts are relevant to the scientific approach to investigating the world

visual arts: The skills outlined in *Designing and making* and the tasks suggested in the exemplars in the science curriculum are equally dependent on the child's aesthetic awareness and craft-handling skills

language: Recording and communicating play an integral role in all stages of the scientific process. Science contributes to extending and refining pupils' vocabularies and encourages them to present their ideas and findings clearly and precisely in oral and written form.

Suggestions for integration

A number of possible themes through which different aspects of the SESE curriculum might be addressed in an integrated, cross-curricular approach are shown on the following pages. Further suggestions may be found in the *Teacher Guidelines for History* and the *Teacher Guidelines for Geography*.

The themes used are not prescriptive and have been chosen by way of illustration only.

The sample units include

- a unit of work from a scheme for *infant classes*. This table illustrates how the theme 'spring' can provide the focus for work incorporating many aspects of units from the SESE curricula. Links to other curricular areas are also indicated

- an integrated theme from a scheme for *first and second classes*. This topic web outlines how the theme 'clothes' can integrate aspects of units from SESE with other curricular areas
- a sample of an integrated science and geography theme suitable for *middle classes*
- a unit of work for *fifth and sixth classes* based on the theme of food. This theme provides for linkage within the strand units in the science curriculum and illustrates how integration with other curricular areas may be planned.

Exemplar 6

A thematic approach to planning in SESE

infant classes

Spring

Scientific aspects

Plants and animals

- observe, discuss and identify a variety of plants and animals in different habitats in the immediate environment
 - common trees and other plants*
 - common birds observed in trees and hedges and visiting the bird table*
- sort or group living things into sets
 - spring flowers, leaves, trees, birds, vegetables*
- recognise and identify the external parts of living things
 - flower, leaf, stem, root*
 - tail, leg, beak, feathers of the blackbird, thrush*
- observe growth and change in some living things
 - reflect on the growth of bulbs and seeds planted in the classroom*
- explore the conditions for growth of bulbs and seeds
 - in soil, damp moss, wet paper*
- become aware that animals and plants undergo seasonal change in appearance or behaviour
 - appearance of buds and shoots*

Caring for my locality

- appreciate that people share the environment with plant and animal life
- develop a sense of responsibility for taking care of trees, plants, flowers, birds and animals in the area.

Geographical aspects

The local natural environment

- explore and discuss some aspects of the physical and natural environments in the immediate locality of the school
 - waste ground, hill, hedgerow, forest, bog*
- observe, discuss and investigate water in the local environment
 - rainfall, puddles and streams*
 - water, sand, stones in streams, ponds, lakes or at the seashore*

Weather

- observe and discuss a variety of weather conditions, using simple vocabulary
 - rainy days, sunny days, foggy days*
- record weather observations using a weather chart or diary
- become aware of some of the effects of different weather conditions on human, animal and plant life in the local environment during spring
- discuss the suitability of different kinds of clothes for different weather conditions

People at work

- discuss the work of people during spring in the home and school, in the local community, in towns or in nearby countryside and in wider environments
- become aware of buildings and places where people work, especially those in the locality

People at play

- become aware of and discuss play spaces and the games played in these play spaces during spring
 - at school, in the locality.*

Historical aspects

Time and chronology

- become aware of and discuss the sequence of events in simple stories
 - the days of the week*
 - the seasons*
 - the life cycle of a frog, sheep, flower*
- record sequences of events using simple time lines
 - the growth of a broad bean*
 - a tree diary*
- listen to some stories associated with the traditions and customs of spring
 - St Brigid and the Brigid cross*
 - St Patrick.*

Other curricular areas

SPHE

- growing and changing.

Exemplar 7

A thematic approach to planning

junior classes

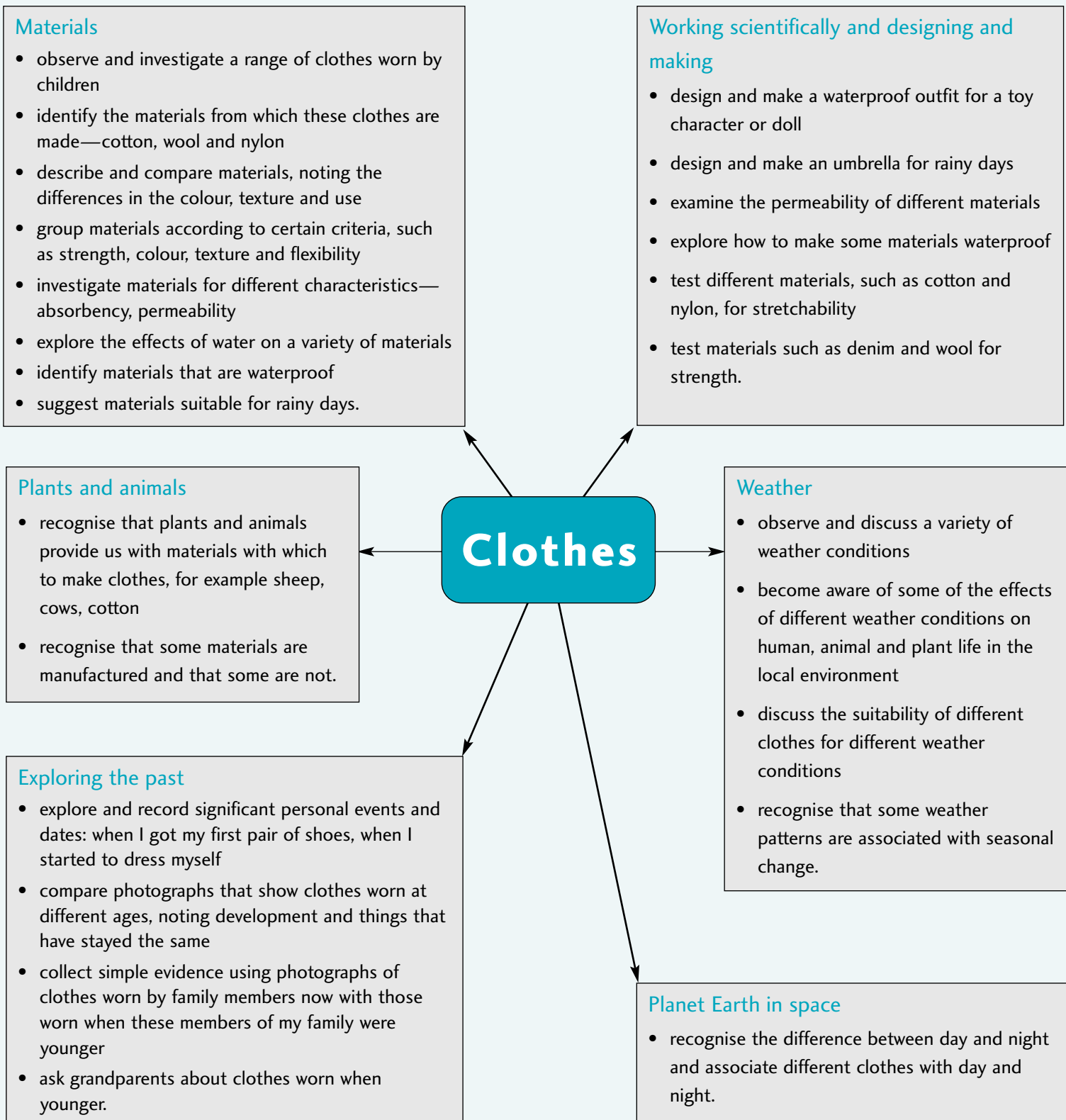

Exemplar 8

An integrated science and geography topic

middle classes

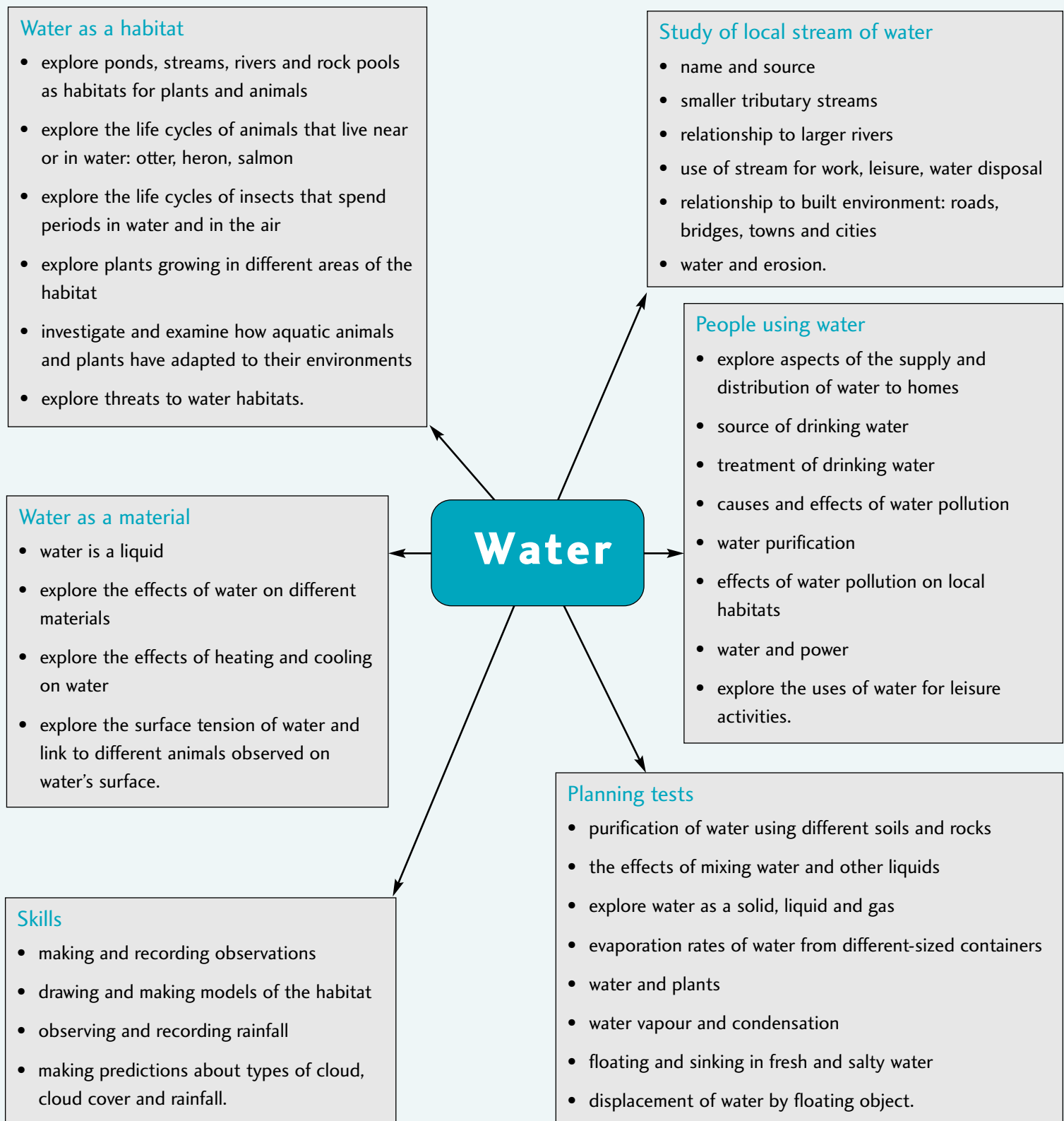

Exemplar 9

A thematic approach to planning in SESE

senior classes

Food

Scientific aspects

Foodstuffs—properties and characteristics

- identify and investigate a range of common foods
- compare different foods—in colour, texture and use
- distinguish between raw and processed foods
- properties of different foods: perishable/non-perishable, solid/liquid
- investigate ways in which foods are packaged
- explore uses of different materials to keep food fresh, compare use of biodegradable and non-biodegradable forms of packaging

Foodstuffs and change

- explore the effects of heating and cooling on different foods
- design, make and flavour different ice-creams
- investigate ways of keeping different foods hot or cold
- design and make a tea-cosy to keep a liquid warm.

Mixing and separating foodstuffs

- investigate how different food can be changed by mixing
- mixing and dissolving materials in water; dried foods
- examine the changes that take place in materials when beaten, whisked, mixed, squashed, e.g. beating together sugar and margarine, whisking egg whites
- examine different ways of separating using a colander, sieve or filter paper

Plant and animal life

- plants and animals are a source of food for people
 - interdependence of animal and plant life for food
 - food chains, food webs
 - investigate how different animals feed
 - requirements that plants have for growth
- #### Energy
- investigate the ways in which energy is used in cooking and producing foods at home and in the locality
 - explore the effects of air and heating on different foods—yeast, milk, chocolate
 - electricity and gas supply to the home.

Geographical aspects

People at work—food and farming

- explore some aspects of the production of everyday foodstuffs in the locality
- environment and work of primary producers, e.g. farmers, the fishing industry
- links between local producers of different foodstuffs

People at work—industry

- work of people involved in manufacturing or delivering important services
- work of factory in locality
- use of natural resources to make and process foodstuffs in locality

Environmental care

- recognise how people have changed and are changing environments for farming and industrial purposes
- biodegradable and non-biodegradable waste from food packaging
- waste food products that can be composted
- suggest ways in which litter from packaging can be removed in locality of school
- collect food packaging for recycling
- investigate the impact of local food industries on the environment
- explore foods from different parts of the world
- identify different methods of cooking foodstuffs in different locations.

Historical aspects

Continuity and change over time—food and farming, shops and fairs

- the different types of farming in the past and now
- type of work that people did in farms, local mills, shops
- crops and foods traditionally associated with the locality
- life, society, work and culture: types of food people ate, methods of cooking food, methods of preserving foods.

Other curricular areas

SPHE

Food and nutrition

- sort and group foodstuffs into different categories, e.g. cereals, dairy foods, fruit, proteins, fats and carbohydrates
- food value of different groups of foods
- concept of balanced diet
- importance of liquids to the diet
- customs associated with food
- foods and festivals.

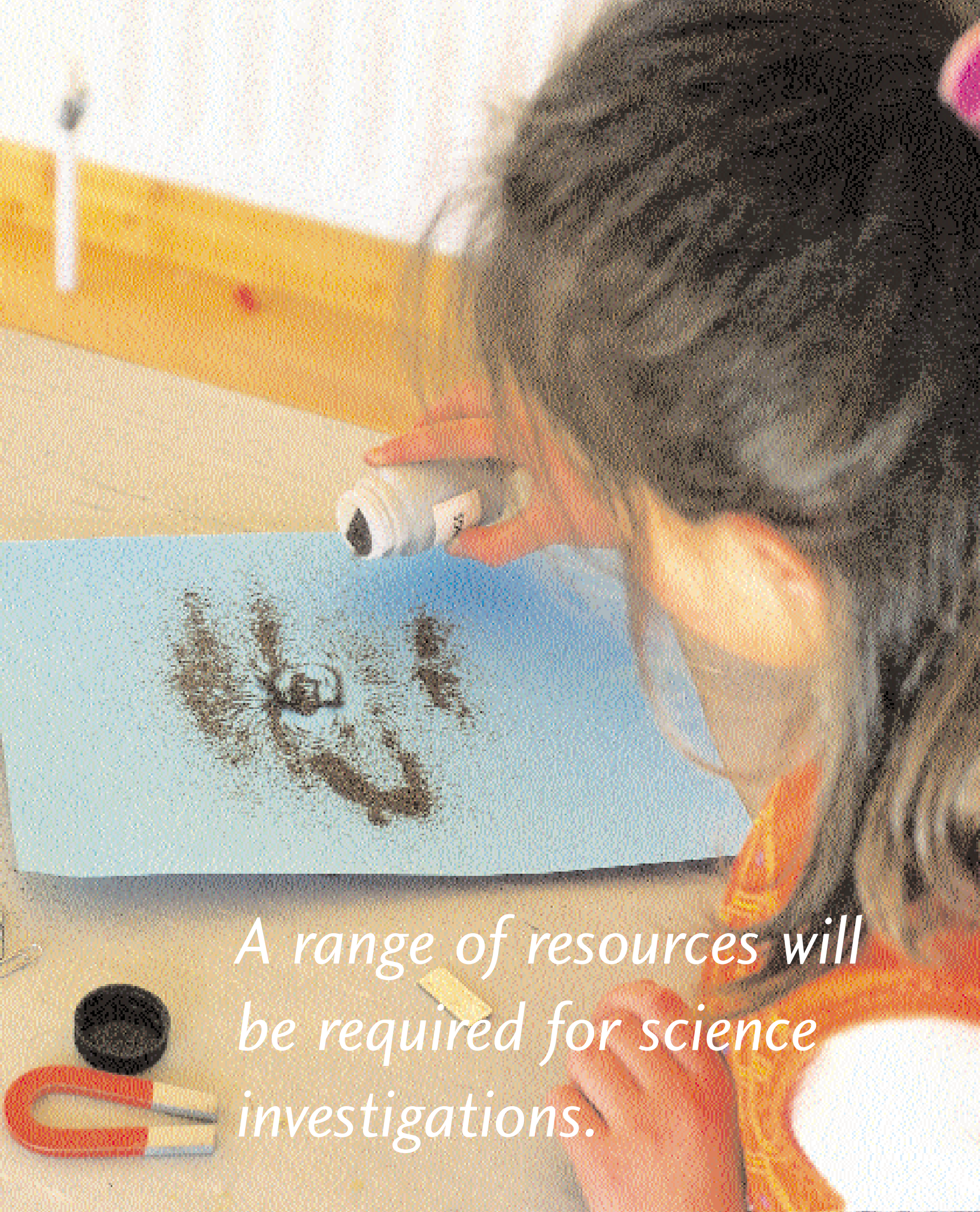

A range of resources will be required for science investigations.

Approaches and methodologies

Approaches and methodologies

The methods and approaches adopted should create a learning environment where

- children's ideas are the starting point for science activities
- practical activity is encouraged
- links with the environment are fostered
- children can apply scientific concepts to everyday situations
- children have an opportunity to work together, share ideas and communicate their findings.

Organising and managing the science lesson

Primary teachers employ a variety of methods for organising learning and teaching. These range from children undertaking individual tasks to whole-class lessons. During the science lesson the teacher may adopt several approaches, such as group work, whole-class work and individual work. The methods the teacher employs to manage the science lesson will depend on the number of children in the class, the resources available, the space available, the activities that are planned and the teacher's own methodological preferences. Different methods of organising the science lesson are outlined here.

Whole-class work

Many teachers work with the whole class at different stages during the science lesson. This method is effective in

- introducing a new science topic or concept
- demonstrating new methods of working
- preparing and discussing with pupils different methods of investigating
- providing background information that may be required for an activity
- directing children's questions and hypotheses
- drawing the lesson to a conclusion, encouraging different groups to report on their investigations
- helping children identify further scientific investigations.

Small groups

Many teachers organise the science lesson so that children can work together in small groups. Different methods of managing small groups are outlined. These include:

- several small groups working on similar activities
- small groups rotating around different activities (circus of experiments)
- small groups working on independent activities that contribute to the overall theme
- one small group working on a science investigation.



Individual work on chosen topics or projects

Children pursue their own studies and carry out investigations that allow them to pursue their own interests and ideas. This method allows children to work at their own pace and in areas of immediate interest and relevance to them, but it is demanding on teachers' time and resources.



A variety of approaches

The use of a variety of approaches and methods will facilitate the efficient implementation of the science curriculum. The nature of the strands and strand units themselves necessitates the use of a variety of teaching methods. The methods chosen should facilitate the achievement of the objectives of the unit of work as well as taking cognisance of the content and context of the lessons. The effective teacher will use a combination of approaches to meet the needs of the pupils and to suit the objectives of the unit of work. The approaches chosen by the teacher should enable the children to work scientifically in a variety of contexts, to undertake practical activities and to tackle open-ended problems and investigations.

Selecting appropriate methodologies and approaches

The methodologies and approaches chosen by the teacher should accommodate the different learning styles of the children and should:

- allow the children the excitement of finding out for themselves
- enable the pupils to work on their own problems as far as possible
- encourage children to pose their own questions

- use children's ideas as a basis for activities. Children should be encouraged to use their own ideas, test and perhaps change their ideas.

Among the approaches that are particularly appropriate for facilitating practical work in science are

- the investigative approach
- the teacher-directed approach.

Investigative approach

Science investigations provide children with opportunities to use and apply concepts while solving a problem that has been set for them by the teacher or posed by themselves. Most teachers will use a combination of closed and open-ended activities.

Closed activities

Activities and problems that help children discover or learn a pre-determined idea or procedure are referred to as closed activities. This approach can be used when the teacher wants to guide the children through the processes and content of science. Teacher-developed worksheets and commercially produced workcards and textbooks may provide a valuable resource for teachers when planning for closed activities and experiments. These materials provide comprehensive instructions that tell the pupils what to do, the equipment required and the measurements to be taken. These closed activities can be an effective way of illustrating aspects of conceptual understanding.

Open investigations

This approach involves the teacher in providing opportunities for the pupils to undertake open-ended activities.

These activities or investigations encourage the pupils to work scientifically and to raise their own ideas and questions, which will then be tested or investigated. Teachers who ask broad or open questions will encourage children to develop an investigative approach to solving problems. Broad or open questions are designed to place the responsibility for thinking on the pupil. They foster divergent thinking.

The extent to which teachers choose to adopt an open-ended investigative approach to science will depend on the age and maturity of the children, the number of pupils in the class and the teacher's willingness to work in an unstructured environment. *Exemplar 10* illustrates the stages involved in developing a problem-solving or investigative approach to science with primary pupils.

Teacher-directed approach

The teacher-directed approach involves the teacher telling or showing the children what to do and in observing their progress. The teacher makes most or all of the decisions concerning the content of the lesson, and the child responds to instructions. This is a useful approach when the teacher wishes to demonstrate skills of using thermometers, separating substances, heating materials or other activities that may involve potential hazards or require the use of delicate or expensive resources. Certain aspects of the science curriculum may not lend themselves to investigative work by pupils; in these instances a demonstration by the teacher would be an appropriate form of practical work.

Direct teaching is appropriate for use when clarifying concepts being investigated and ensuring that safety practices are being applied. It can feature, therefore, as part of the teacher's approach in a wide range of lessons.

Exemplars

Exemplars are included throughout this section of the guidelines. Many of these contain lessons or units of work illustrating

- how the children may work scientifically
- the detailed content of the lesson or unit
- some methods of assessment.

In some of the sections the examples used are linked to particular classes in the school. However, this is by way of illustration only; most of the techniques described can be adapted for use at all class levels. The activities suggested in these guidelines offer a range of possibilities, but individual teachers will have to use their professional judgement to decide which methods and approaches are best suited to the needs of their pupils.

Exemplar 10

Approaches to planning open-ended investigations

In a problem-solving model of science education, children will learn to use, refine and develop the skills of working scientifically. The stages involved in such a process are:

Exploration (involves observing, asking questions, hypothesising)

The first stage involves children having access to materials associated with the topic. For example, in an investigation of sound, children will have opportunities to explore a range of musical instruments and different metals. They will use their senses to explore the materials and will make comparisons between different materials. They might classify materials and put them in order of instruments that make the quietest to the loudest sound.

Children will be encouraged to record what they discover or find interesting about the materials. The teacher will focus on interactive discussion with the children to elicit their ideas and to find out their existing ideas about the topic to be taught. The comments and questions from the teacher before and during these activities may provoke questions, predictions or hypotheses, which the children can then test by investigation.

Investigating (involves planning and carrying out investigations)

The stimulus for investigations comes from the pupils' observations, experiences, questions and interactions in small groups or whole-class situations. During this period the children will plan their investigations based on their own questions and ideas. The teacher will guide and observe the children's activities and will help refine their investigations by asking questions such as

- *What are you trying to find out?*
- *What ideas have you got for your investigation?*
- *How will you investigate?*
- *What do you think will happen?*

The role of the teacher will be to focus children on aspects of their investigations that need to be refined or developed.

Implementation stage

The implementation stage begins when the pupils choose their equipment, use measuring instruments and manipulate the variables in their investigation. The central idea is to help children construct and carry out fair tests.

The teacher should work with individual groups and children in helping them to identify the most important variables to be changed or to remain stable.

- *What are you changing? Why are you changing these?*
- *How will you measure the change?*
- *How will you measure the outcome of the change?*
- *What things are being kept the same to make it fair?*
- *Is this a fair test?*

Conclusion

At the end of the investigation the whole class will regroup to clarify and share ideas. During this stage each group will show and describe their work and their findings. This will encourage them to reflect on the diverse approaches adopted by different groups in approaching the same task.

The teacher will help the children to recognise the significance of their results by asking questions such as:

- *What did you find out?*
- *Was the result what you expected?*
- *Was it a fair test?*
- *Did you choose the best way of recording your work?*
- *Who would find your investigation useful?*
- *What would you change if you repeated this investigation?*
- *Has the result changed any of your ideas?*

Encouraging children to make decisions about how to do investigations means that different groups will work in different ways. A number of lines of enquiry may be pursued, and there is the possibility that they will lead to a diversity of results. It may mean that different groups and individuals learn different things from the practical work.

Learning about plants and animals

The environment in which plants and animals live is called a habitat. The habitat also involves the physical surroundings or non-living aspects of the environment, such as light, temperature, water, oxygen and nutrients.

The habitats in the locality may include a

- hedgerow
- footpath
- lawn
- tree
- wild area
- wasteland
- pond
- stream
- river
- woodland
- meadow.

A variety of plants and animals of different habitats should be studied by children at each level. Opportunities to visit and explore a range of habitats in the local environment are central to the development of children's ideas about the diversity and life processes of living things. Investigative work based on the animals and plants that are observed and explored in different natural habitats may be undertaken in the classroom. Caring for animals and plants and understanding their needs for growth and development will enable children to observe, measure and record the changes taking place in organisms over an extended period. These school-based investigations will supplement and support the work in the outdoor environment but they are not an adequate substitution for the first-hand exploration and discovery by the child.

Identifying habitats in the local environment

Before undertaking outdoor investigations teachers should become aware of the range of habitats in the area and should identify those habitats that can be compared and contrasted. The study of a natural habitat such as a hedgerow, sand dune or woodland may be more accessible for schools in rural areas. However, children both in urban and rural schools will have access to habitats such as a piece of wasteland, a tree, a footpath and its verge, or a wild area in a garden. It is also possible for schools to create habitats, both inside and outside. A school garden can be made using an old sink, barrel or car

wheel. The basic requirements of soil, water and rocks can be assembled and appropriate animals and plants introduced.

The habitat selected for study can be quite small. During the early years it is recommended that children study small areas, so that their attention is focused. An area of one or two square metres can be selected and marked out using pegs and string. These habitats or selected areas of interest may be within the school grounds, under a tree in the nearby park or by a hedge.

The extent of the habitats and environments that the child will study and explore will increase as the child grows older. In the junior classes habitats such as a tree, a grassy area or a pond may be introduced. Children can create their own habitat from logs and stones in a quiet area and observe the animals and plants that are attracted there. In the *middle classes* the habitats studied will be based in areas where children live and play, for example a woodland, a stream or waste ground. In the *senior classes* children may study a habitat in the locality and compare and contrast this habitat with one in a more distant place: for example, children may study a deciduous forest and compare and contrast it with a coniferous forest. The progressive expansion of the habitats explored reflects the child's developing ability to work in the environment and his/her understanding of a widening range of scientific concepts and methods of working.

Extend the range of sites to be explored, from school grounds to the locality and then to different places such as areas of grassland, woodland, sandy and rocky seashore, meadowland and bog.

The teacher should be thoroughly familiar with the habitat that will be visited and explored.

Children should have a clear sense of the purpose of the visit.

Approaches to outdoor exploration and investigation

Preparing for outdoor exploration

Comprehensive guidelines on the planning and organisation of fieldwork are provided in the *Teacher Guidelines for Geography*. However, there are specific requirements to ensure that successful scientific investigations are undertaken in the outdoor environment.

Knowing the environment

The teacher should be thoroughly familiar with the habitat that will be visited and explored. Teachers should visit different habitats that they plan to investigate with children at different class levels. These preliminary visits will clarify the potential of the environment for scientific investigation and will focus on the teaching strategies to be adopted. Records of habitat surveys should be kept on file in the school, and these will provide a valuable resource for teachers.

The teacher must also have a clear idea of the contribution of the proposed visit to the children's learning and the areas of scientific knowledge and skills that can be developed. Consideration should be given to questions that children may ask from their observations of the environment. These questions will provide starting points for the children's investigations. The

teacher may identify some investigations that can best be pursued in the field and those that would be more profitably explored in the classroom.

Working safely in the outdoor environment

Outdoor work should be based in areas that are accessible for children, teachers and helpers and that are safe.

Preliminary visits by teachers to the site can be used to identify potential hazards. If there are apparent dangers then a more suitable habitat should be selected for study. Habitat studies involve children in working with plants and animals, and teachers should be aware that many children are allergic to some animals and plants.

Adequate supervision should be given to the children at all times. As most outdoor investigations will involve children working in small groups, it will be necessary for a number of adults to accompany each class. These adults should be aware of the hazards that may be encountered and the procedures to be adopted in the event of emergencies.

Preparing for work outdoors

It is advisable that teachers should help children to prepare for scientific work outdoors. The children should have a clear sense of the purpose of the visit. They may need some factual information about the habitat before their visit: for example, they may use secondary sources to provide some basic information about the development of bogs and peatlands. This information will help them to focus their observations, refine their questions and suggest ways of recording on the site. Preparatory work of this nature can ensure that time spent working outdoors is profitable.

Children may also need to practise using some equipment. The use of pooters, sweep nets and magnispectors can be demonstrated by the teacher and practised by the children in the classroom and school grounds. Children can develop confidence using different methods and procedures, such as taking measurements and reading thermometers, before they begin their outdoor work.

Choosing activities for outdoor work

Work in the outdoor environment can incorporate a range of activities and investigations. The activities selected will depend on the age of the children, their previous experience, the time available and the nature of the site. If a large group or whole class is being taken on an initial visit then one or two activities that focus on a small number

of features in the environment will be sufficient. Opportunities for children to observe, ask questions and propose ideas to be tested should also be provided. It may not be possible for the children's ideas to be tested or investigated during an initial visit. Follow-up visits and classroom work can be used to encourage them to explore habitats in a scientific way.

As children develop more experience of working outdoors, a greater range of activities and explorations may be undertaken. Children in *middle* and *senior classes* who have developed a range of skills and knowledge of environmental investigations will be encouraged to ask their own questions and to undertake tasks that they have devised for themselves. Activities that encourage group participation and activity are recommended. These activities should enhance classroom work and develop children's social skills and should avoid repeating experiences of earlier years.

The teacher should also decide on the duration of the habitat study, as this will affect the type and nature of activities undertaken by the children. Work on a local stream, hedgerow, farm or seashore may be undertaken on a seasonal basis, and children could repeat activities at regular intervals over a year. Outdoor work that is long-term should be used by the teacher as a springboard for activities in other related areas, such as history and geography.

A conservation code may emphasise the need to

- search carefully and cause as little disturbance to the surroundings as possible
- handle animals and plants with care
- replace stones and logs that are turned over
- observe, draw and record, if possible, rather than handling
- return animals to habitats as soon as possible.

Collecting living things and conservation

The indiscriminate collection of plants and animals should be discouraged, and children should be aware of the importance of conserving the natural flora and fauna in the environment. Children should be encouraged to make a list and perhaps a count of animals and plants that they find. The observation, recording and sketching of living things during outdoor exploration should largely take the place of collecting. Where regular visits to a habitat can be made to observe progress and change, nothing should be picked or collected.

Animals and plants should only be removed from their environment when an investigation cannot be carried out there. It is recommended that children discuss what they intend to collect before beginning their outdoor work. The teacher should organise it so that each group of children collects only one sample of each plant or a very limited number of samples. The collection of plants and animals should be carried out under the direct supervision of the teacher or another adult. **Arrangements should be made for the return of animals to their habitats.**

Teachers can encourage children to care for and respect plants and animals and take action to protect the environment. Children could devise a conservation code for themselves before working in the outdoor environment. The code can be agreed as part of the preparatory work and revised after initial explorations outdoors.

Implementing follow-up work

A programme of work based on the observations made by the pupils during their outdoor investigations is essential if the full potential of outdoor work is to be realised. Follow-up work can involve the pupils in

- discussing and comparing the findings of various groups
- analysing and interpreting the information collected
- using secondary sources to identify animals and plants observed in the habitat
- grouping and classifying animals and plants
- undertaking investigations with living things
- organising displays of their drawings and records.

Approaches to investigating habitats

Using a range of investigative techniques

A number of teaching and learning activities may be used to help children develop their ideas about plants and animals that populate different habitats. Children should investigate the conditions needed for animals and plants to exist and explore the preferences shown by plants and animals for particular environments. A range of investigations that focus on living organisms are discussed in this section.

Starting from the children's ideas

The teacher can ask the children to consider the kinds of places where animals and plants live. The children can then identify and record as many different places as possible where they find animals or plants living. They will suggest places such as

- stones
- trees
- walls
- grass.

The children's ideas may be used as the starting point for the habitat investigation. Books, videos and other secondary sources can extend children's knowledge of the variety of places in which plants and animals can be found. Drawings and annotated sketches can help them to reflect on the different types of habitats where various organisms live.

Comparing habitats

In the *middle* and *senior classes* children should begin to compare and contrast the animals and plants found in similar habitats. Such studies may compare

- the plants and animals inhabiting two ponds, in shaded and sunny positions
- the different types of animals found in oak trees in the same wooded area
- the variety of weeds found between cracks in footpaths of urban areas.

Exemplar 11

Initiating observations in the outdoor environment

all classes

The location of the habitat

The following questions will help children to familiarise themselves with the habitat and to become aware of its physical location in relation to the school:

- How far is the habitat from the school?
- How long does it take to get there?
- In which direction did we travel?
- What towns or townlands did we pass through?
- What rivers did we cross on our journey?
- What mountains and hills did we see?
- How was the land used in these areas?
- Did you see any human activities in the environment, such as cutting of hedges, draining land, ploughing land?
- Did you observe any other habitats en route to the site?

Initial explorations

When children visit a habitat it is recommended that a short period (5–10 minutes) be set aside for them to become familiar with the environment. They can be asked to sit quietly and observe aspects of the habitat. The following questions will sensitise them to features of the habitat:

Sound

Encourage children to shut their eyes and listen to sounds.

- What can you hear?
- How many different sounds can you hear?
- Can you hear bird song?

The children may use a tape-recorder to record different sounds heard in the environment.

Colours and shapes

- What colours can you see in the habitat?
- How many shapes can you see?
- What leaves, bushes, flowers can you see?
- What is moving in the habitat?
- What animals can you see?
- What lives in the shady areas?
- What lives in the sunny areas?
- What is flying overhead?

The children should take photographs or make sketches of things of interest.

Touch

Encourage children to feel some soil.

- What does it feel like?
- Can you roll the soil in your fingers?
- Describe the soil: is it hard or soft?
- Are there differences in the soil at different places in the habitat?

Smell

- What smells or scents can you get?
- Which flowers have the strongest scents?
- Can you smell the grass?



Investigating living things

Exemplar 12

Observing and recording in the natural environment

Observing and recording environmental features

Children should be encouraged to observe and record features of the environment that they are investigating. The children should

- observe the location of the habitat and its relation to other habitats, buildings and features of the natural and built environment
- observe and record the different materials that make up the habitat, such as wood, soil, stone and water
- measure the size of the habitat, using standard or non-standard units
- make a sketch of the area on a worksheet. Emphasis should be placed on the recording of useful information, e.g. location of a river, hedge, grassy area, trees. These sketches should be used by different groups to record the areas they investigated so that they can return to the area and make further records for comparison with the records of their first visit
- draw maps of the area or use prepared maps to illustrate the main features of the area
- record the climate of the habitat. Temperatures in different parts of the habitat and at different times of the day and year should be taken, and the amount of sunlight or shade in different parts of the habitat should be recorded. Wind strength and wind direction may be measured.

As well as environmental features, the types and numbers of living things in the habitat should be observed and recorded. It may be helpful for the teacher to divide the class into small groups to explore the site and see how many different kinds of animals they can find.









Encourage the children to examine the area closely, looking at the underside of leaves, in cracks in the earth, under stones, on walls and at pieces of wood. Initial explorations should focus on a small area at a time. Children can record their findings in various ways.

Developing observation through questioning

After a short period the children may be brought together to compare and to describe the animals they have observed. *Exemplar 13* provides some questions that will help children to clarify their observations, stimulate them to measure and compare the animals observed and aid in their identification.

The main objective for children studying animals is to find out about them, rather than to name them. It will not be possible for teachers and children to name everything they discover. However, common animals will be identified, and children may discover a lot of information about them through their observations and investigations. Guidelines on the identification of different living things are provided in *Exemplar 15*.

Record of minibeasts found on 20 June

Nettles	Leaves	Wood	Tree trunks	Soil
				
				
				



I-spy method

This activity is appropriate for children in infant and junior classes. The teacher prepares the children to look for a small number of common plants and animals. During their preparatory work in the classroom they use secondary sources, such as photographs or pictures, to identify a limited number of plants or animals. Workcards illustrating the animals to be found in the habitat may be provided. The workcards can be used to record the number and location of each animal. When the children can identify a limited number of animals they can search for these in several places in the habitat.

Searching and observing sets of animals

As children develop experience of searching for animals it may be helpful to give each group responsibility for finding and identifying particular types of animals with different characteristics. These may include:

- many legs, without legs
- shells
- wings
- feelers
- scales
- animals that live alone or in groups
- animals that live on the ground or under stones.

As part of an extended investigation the children could return to the habitat several times, perhaps in different weather or at different times of the year, to see how the population changes.

Keeping a diary

The children can keep a diary of a habitat and record the variety of animals and plants observed at different times during the year. A diary will also encourage observation of the growth and development of plants and animals at different stages of their life cycle. Drawings, photographs and measurements should be recorded in the diary to supplement the written entries.

Making drawings based on close observation

Children should be provided with opportunities to make observational drawings of different animals. Small animals or minibeasts should be placed in a viewing container, and the children should look as closely as they can at them with a magnifier. Animals such as slugs, caterpillars, spiders and snails are slow-moving and can be easily observed.

Encourage the children to pay close attention to details of the animal's shape and proportions, where it is jointed, and textures and patterns of different parts of its body. This work requires concentrated looking, and as children draw they should observe many features of the creature that they may have previously overlooked.

Making a series of drawings

A series of drawings is one of the most effective ways of recording the stages of an event, such as a spider spinning its web or a worm moving on the surface of the soil.

Children can make drawings on separate sheets of paper and these can be displayed in sequence. The activity of drawing will help them to focus on what is happening, and the drawings will provide a detailed record to which they can refer.

Annotated drawings

After a visit to a habitat the children are asked to draw an annotated picture of the habitat, showing some of the plants and animals that live there. The teacher will discuss the children's drawings and ask them to consider:

- Is this a good place for these animals and plants to live?
- Are these animals and plants always found together?
- How do the animals rely on the plants in this habitat?
- Where do the animals find shelter?
- Can you see fur, feathers, droppings, food remains, tracks?
- Are there any signs of how the animal influences the habitat, for example worm casts, digging holes or burrows, eating vegetation?

Discussing these questions provides an insight into children's understanding of the environmental influences on a habitat and the kinds of organisms the environment supports. It will also encourage children to question and to use their questions to devise investigations for themselves.

Exemplar 13

Developing observation through questioning

all class levels

The following questions will encourage children to observe, describe, compare and measure animals.

The structure of the animal

- Can you tell if it is alive?
- How big/long/tall/heavy is it?
- How many
 - legs
 - wings
 - eyes
 - tentacles has it?
- Is the body hard or soft?
- How many body parts has it?
- Has the animal got
 - stripes
 - scales
 - rings?
- Can it see/hear/smell?
- Which animals are similar to each other?
- Which animals are different from each other?

Feeding habits

After repeated observations in the classroom the children should ask questions such as:

- What does it eat?
- Which food does it prefer?
- How does it eat?
- Does it hold its food?

- How much does it eat?
- Does it drink?

Where they like to stay

- Does it like
 - dark/light
 - wet/dry
 - cold/warm places?
- Does it stay
 - on the ground
 - on trees
 - in holes
 - under the soil
 - in water?
- Where does it sleep, and for how long?
- Does it make its own house?
- Does it move around, or does it stay all the time in the same place?

How they move

- Does it
 - walk
 - crawl
 - jump
 - hop
 - fly
 - swim?
- Does it move all the time?
- Does it move quickly or slowly?
- Is it noisy when it moves?

- For how long does it rest?
- How far does it travel in a minute?
- How fast does it move?
- Does it leave tracks?
- Can you recognise the animal by its tracks?

Relationship with other animals

- Does it live alone?
- Does it live with other animals?
- Does it live with animals of the same type?
- Does it communicate with other animals?
- Has it got a bite or a sting?
- Can it defend itself?
- When it comes in contact with another animal, how does it behave?

How they reproduce

After caring for and maintaining animals in the classroom for short periods the children should ask questions such as:

- Can you identify the male and female?
- How do they mate?
- Does the female produce eggs or young?
- How many eggs or young does it produce?
- Are the young similar to or different from the parents?

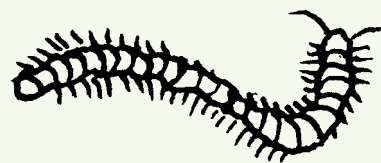
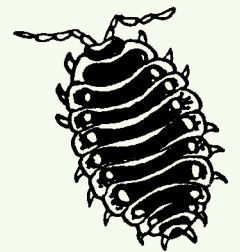
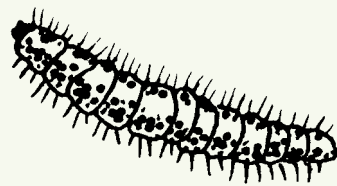
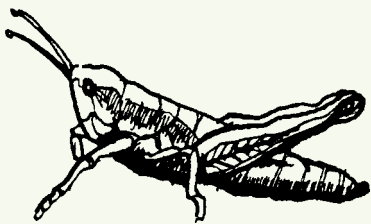
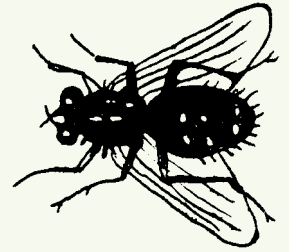
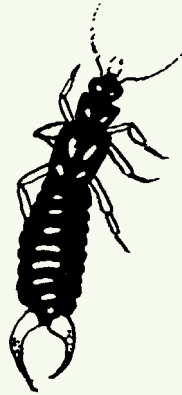
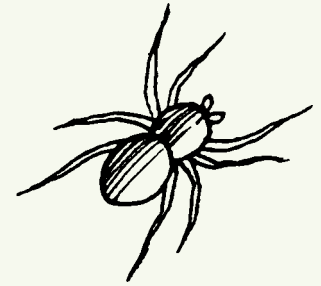
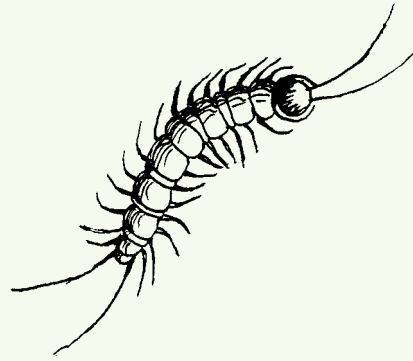

A minibeast is a small animal that can be found in water and land habitats.

Exemplar 14

Exploring, observing and recording plants in a habitat

Children can observe and record the type and number of plants in the habitat. Simple frames (1 square metre), called quadrats, may be used by the children to help them focus on small areas of ground. Hoops may also be used and are more appropriate for children in the infant and junior classes. The primary aim must be to encourage children to look and see differences.



In the summer, children in infant classes may be taken outdoors to look at a grassy area. Each group will lay a hoop on the grass and carefully examine the plant growth inside their hoop. At first, naming the plants is not the main concern: for children in infant classes it is enough that they recognise that many different plants are present in the grass. They should describe the plants observed, noting the colour, shape and number of leaves and petals.

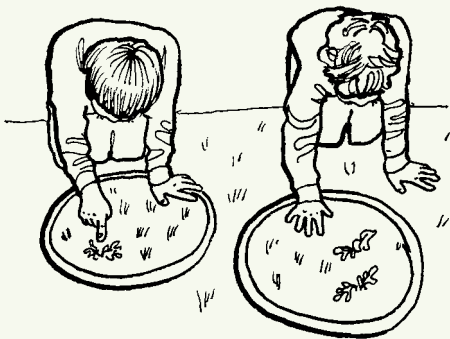

Children in first and second classes will also observe the plants found in their hoops, and common plants found in lawns or playing-fields, such as daisy, dandelion, plantain, buttercup and

clover, can be identified. Workcards that are based on the I-spy method can be used by the children to aid in the identification of different plants.

Children can make a count of the number of different plants found in their hoops or quadrats and record their results. These results can be compared with their records of plants in different areas of the lawn to see if any variation occurs. Children should be prompted to focus on their observations and to clarify their ideas through questioning:

- Do you always find daisies and dandelions growing in the same habitats?
- Would you find the same plants growing here in spring?
- Why are there more dandelions growing in this area?
- Did you find different grasses?
- Did you find similar plants growing in the school garden and in the wild area?

Making estimations

In the middle and senior classes children will make an estimation of the numbers of plants in a habitat. A coding system or a scale against which they can consider their estimations will be required. Before outdoor work begins, children should reach agreement, through discussion, about the approximate quantities to be represented in their scale. Then their individual observations can be compared. A scale such as this may be devised:

Term	Symbol	Description
Full	F	Plant covering the whole site
Plentiful	P	Enough plants present to cover about three-quarters of the site
Many	M	Enough plants present to cover about half the site
Some	S	Plants present will not cover more than a quarter of the site

In the senior classes a bar chart of the frequency of plants can then be drawn. This makes it simpler to compare it with the vegetation from other habitats.

Observing plants in different zones

Plants and animals may be found in distinct zones or bands. 'Zonation' often happens across a pond or in a bog where the various depths of the water or turf provide different environmental conditions. A transect shows how the plant and animal life changes within an area.

Children tie a piece of string to bamboo rods that have been placed in the soil. All the plants that grow in this line are observed and identified. The names of the plants observed in the line are recorded and the height of each plant noted.

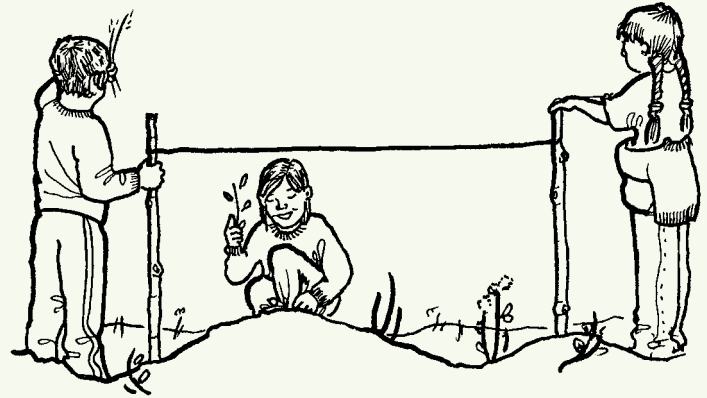

The children can record the name and height of the plants found along the line.

Name of plant	Height of plant
nettle	20 cm
ox-eye daisy	24 cm
dandelion	15 cm
clover	7 cm

Exemplar 15

Classifying and identifying living things

During habitat surveys and work in the outdoor environment, teachers and children will find animals and plants that they may never have observed before or that they are unable to identify. A large variety of living things can be found even in the most common habitats, and it is not expected that children will be able to name all the organisms they find. Rather, they can be guided to identify common plants and animals through the use of identification charts, books and keys.

The identification and classification of living things are closely related activities. Identifying organisms depends on picking out their distinguishing characteristics, while classifying living things depends on recognising their common features.

Living things can be grouped or classified in many different ways, according to their characteristics. These may include:

- observable features such as colour, shape, size, and parts of the body

- where the organism lives
- how it behaves
- methods of feeding
- how the organism reproduces.

Starting from the children's ideas

Ask the children to consider the different kinds of animals they can think of. They should write down what they think in a list, draw pictures or communicate their ideas in a one-to-one discussion with the teacher or as part of a larger group. They can consider questions such as:

- Why do you think it is an animal?
- What helps you to decide that this is a plant?

Similar techniques can be used for plants and animals.

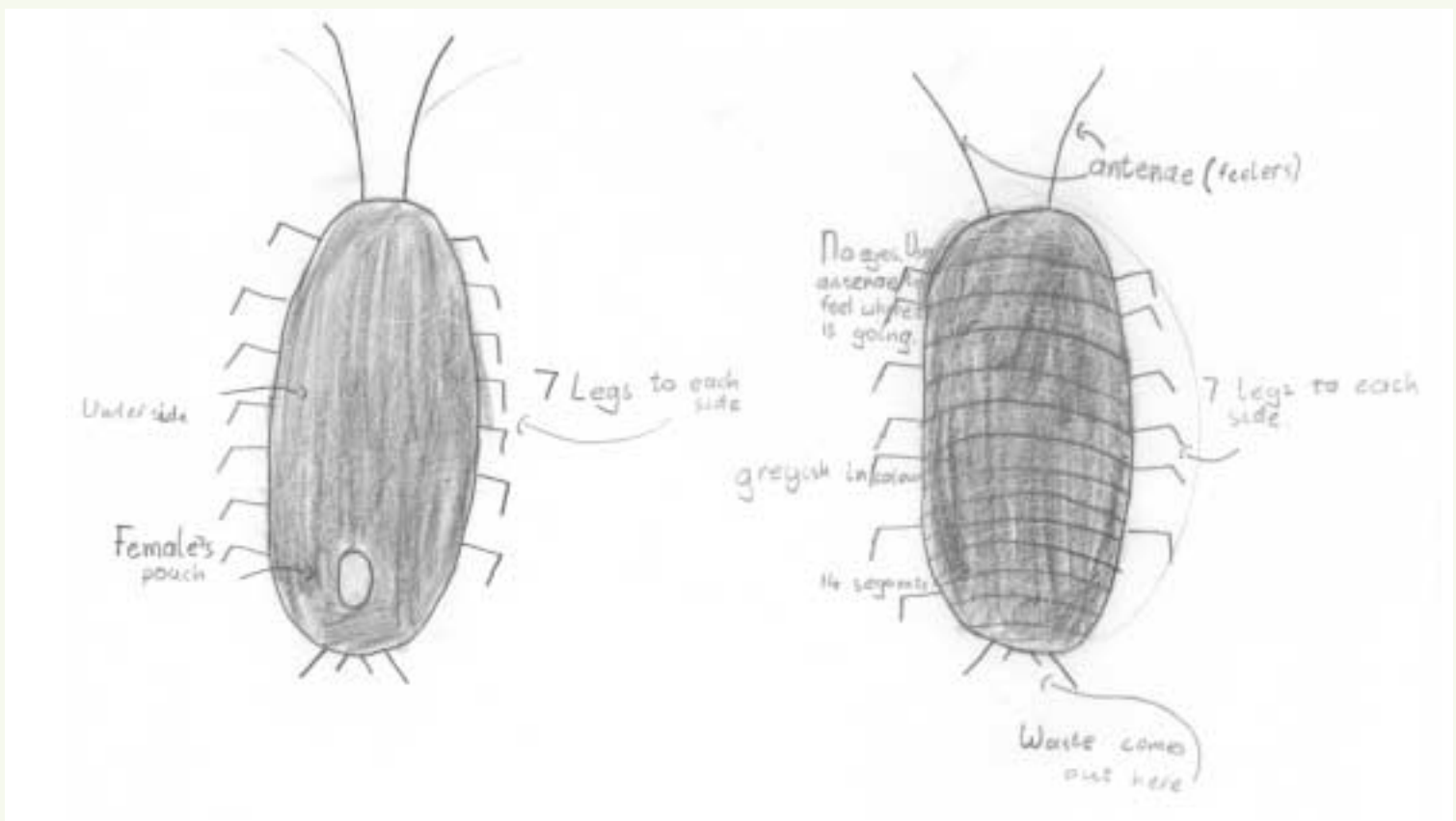

The encouragement of careful observation of the animal or plant and its special features will assist with its identification and classification.

Making accurate observations

The important prerequisite for using identification keys, books and charts is for the child to be able to describe accurately the animal or plant observed. *Exemplar 13* details the types of questions that will help children to focus on the shape, colour, body parts and behaviour of animals. Once the organism has been described, the teacher should develop the observational task by asking the children to compare two or more animals or plants. When children are comparing organisms they should be encouraged to

- describe features such as colour, shape, size and structure
- identify common features
- identify differences.

Making sets

Children in infant and junior classes can sort plants and animals into groups using cards with pictures of animals and plants on them. The different categories into which they will sort the animals or plants can be agreed beforehand: for example, they may sort them into groups of animals with two legs and animals with four legs. Teachers will find that hoops are useful for this type of activity, as the children can place the picture cards into the appropriate hoops as they group and regroup.

Children in middle and senior classes can sort animals or plants into sets using their own criteria. At first they may group according to colour and size. As they become more familiar with the features of the animals they will think of different ways of grouping and regrouping animals:

- make a group of animals with wings
- make a group of animals with shells
- make a group of plants with yellow flowers
- make a group of animals with fur or hair.

Their results can be recorded pictorially or in diagrams.

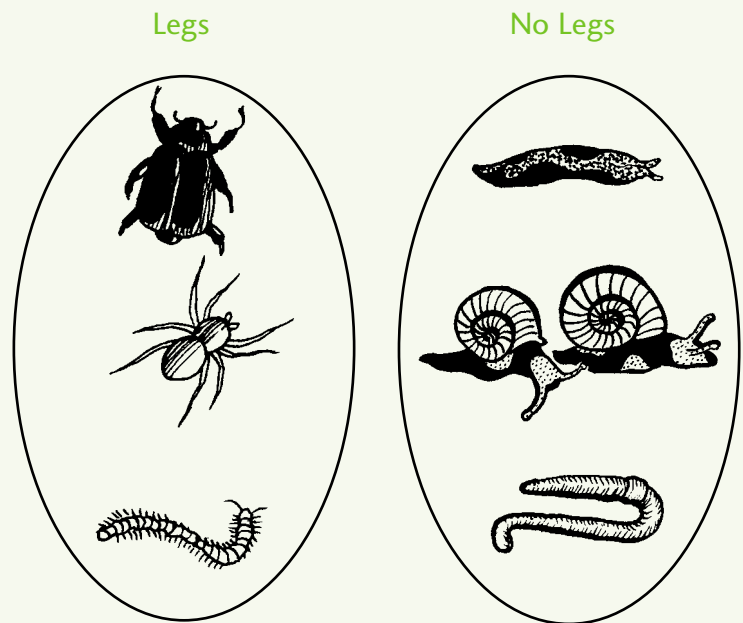

The children may then be encouraged to look at each of the sub-sets in turn and to choose a question that will help divide that into further sub-sets. The children can sort to make sub-sets in this way.

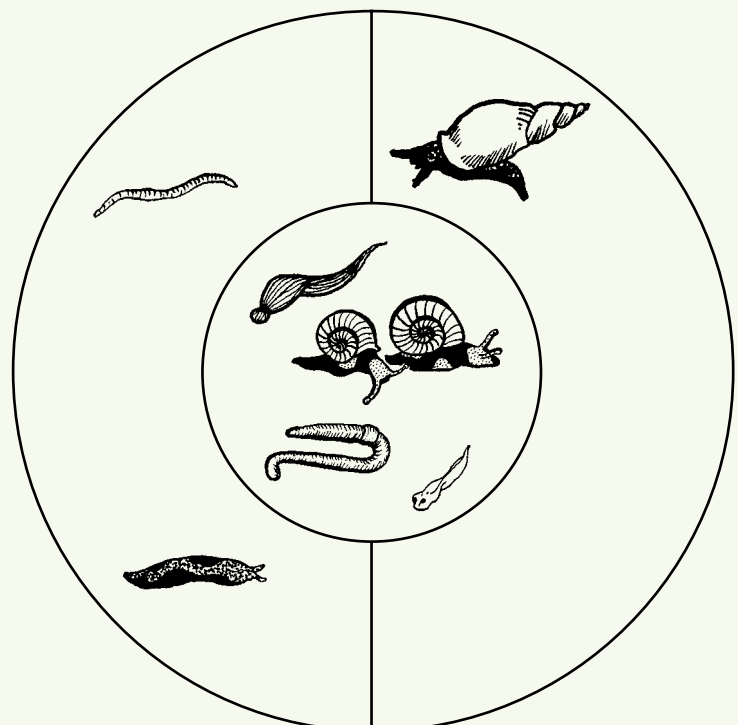

Using keys

Keys are useful in helping children identify animals or plants. There are commercially produced keys that help identification. Pocket guides are useful in identifying features of animals and plants. However, helping children to produce their own keys may often reveal their ideas and level of understanding.

Children use and develop keys by sorting the plants and/or animals in the whole set into two groups. They can then divide each of these into two further groups, and so on until they end up with only one plant or animal in each group. The results of these yes/no groups might be recorded like this:

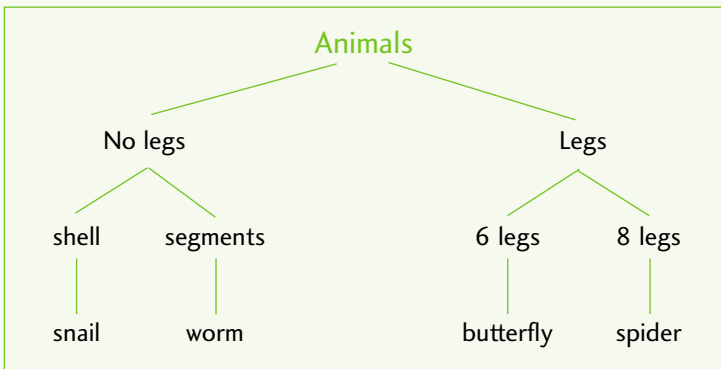

The following example shows a key presented in a different way, by means of questions rather than group characteristics. The children who made this key examined a set of winter twigs found in and around the school garden. The twigs studied were from the oak, horse chestnut, ash, beech and lime trees.

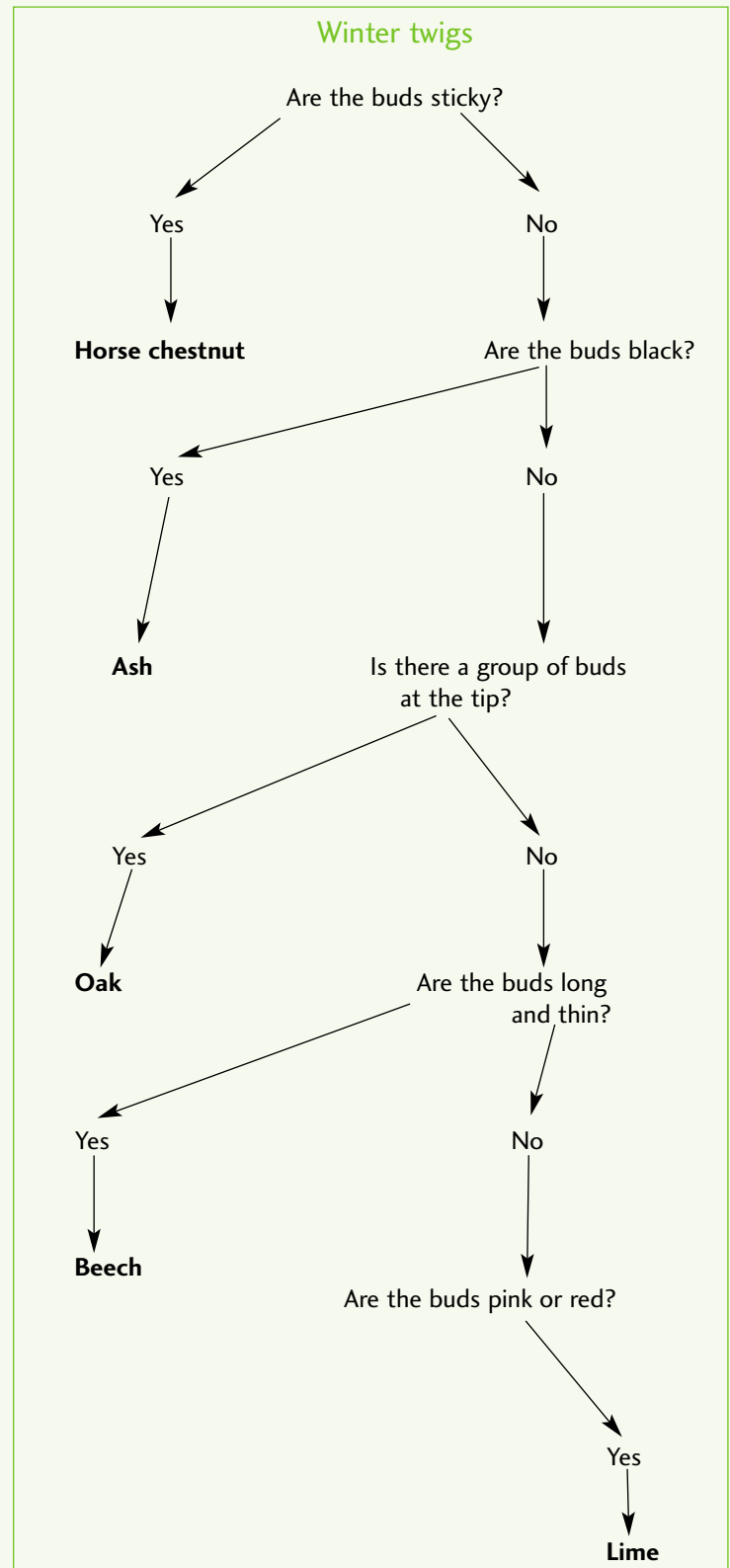

A branching key for the identification of winter twigs

Exemplar 16

Investigating a freshwater pond

middle classes

A small freshwater pond is an ideal habitat for primary children to study. Ponds can be found in urban and in rural areas. Most of our inland canals have very similar characteristics to ponds and provide essentially the same habitat for wetland creatures. Late spring and summer are the best times for practical work with ponds, streams and rivers.

Preparing for the habitat study

Safety

Successful and enjoyable pond investigations require sensible planning, good supervision and adherence to safety rules. The following guidelines should be noted:

- children should work in small groups, under the direct supervision of an adult
- only one group, of between four and six children, should dip at a time. The other children should be positioned well back from the edge and be actively engaged in observing weather conditions, plant and animal life
- use only safe areas of the surrounding banks, from which children can pond-dip or collect samples of water
- children and adults should wear protective rubber boots
- skin infections, grazes or cuts should be covered
- children and adults should be made aware of the position of lifebelts and safety notices in the area
- children should wash their hands before and after handling animals, plants or soil
- children should not handle anything that may be hazardous
- ponds with an algal bloom or water pollution should be avoided. During preliminary visits teachers can assess the health of the pond, and water that has been contaminated with chemicals should be avoided.

Equipment

Pond-dipping provides children with opportunities to design and make a variety of pond nets from materials such as curtain netting, coat hangers, broom-handles, bamboo canes, stockings and muslin. Other equipment will also be required. Make sure that each group has access to

- a flour sieve for investigating the bottom mud
- a white plastic tray or margarine tub for holding the catches
- buckets and pots for collecting water samples
- small plastic containers for holding individual plants and animals
- magnifiers and nature viewers
- plastic spoons and soft-haired paintbrushes for transferring animals from trays to containers
- large screw-top plastic jars for carrying specimens
- identification aids, books and leaflets
- a towel
- clipboards, pencils and workcards, which are kept in large clear polythene bags.

An aquarium (plastic tank) should be set up in the classroom to house some specimens that require further investigation. Add some clear pond water (about one-third of the capacity of the tank), some pondweed and stones. The classroom aquarium and the white trays used for housing catches at the pond should be kept out of direct sunlight. Carnivores should be placed in separate containers.

Finding out the children's ideas

Before visiting the pond it is helpful to establish the children's ideas about ponds and pond life. Ask the children to consider the kinds of animals and plants that live in a pond.

Children can make lists or drawings of the animals and plants that they think might be found there. Older children may make sets of the animals and plants they think they will find underwater, at the water's edge or in the air.

It is advisable that children be able to recognise some water animals before going on their first visit to the pond. These animals may include the great diving beetle, water boatman, dragonfly and damselfly nymphs. Secondary sources may be used to help children identify common animals before their pond visit.

Observing and recording environmental features

On arrival at the pond children may

- make a map of the area, sketching in features of the habitat. The presence of houses, factories, farms and roads in the nearby area should be recorded
- measure the length and width of the pond at different points (see *Teacher Guidelines for SESE: Geography*)
- look at the area surrounding the pond. Record whether the incline of the banks is steep or gentle
- record the air and water temperature. Children should observe the parts of the pond that are shaded or in direct sunlight.

Assess the use of the pond. Children should look for signs of how the pond is used by animals and/or people:

- look for evidence of water entering the pond from different sources, such as a small stream, drainage pipes or run-off from land
- look for evidence of water leaving the pond

- look for various footprints in the soft mud by the side of the pond
- record the numbers of birds seen and any feeding habits observed. Children should draw sketches of birds and write down as many details as possible. These descriptions and diagrams will assist in their identification.

Investigating pond water

The children will observe and examine the water to see how clean it is and whether it is moving or stagnant. Samples of water from different parts of the pond can be taken, stored in separate containers and labelled. Care should be taken that the bottom mud is not stirred. The children should record whether the water is clear or muddy. The smell and colour of the water should also be noted.

The speed of the current

Children can determine the current speed of the pond or canal using the float method. The time taken for an orange to float between two points a known distance apart should be noted.

Observing plant life

Children should observe the plant life of the pond and identify the trees and shrubs growing nearby. Record the plants that occur at the pond edges. A line transect, crossing from a marsh zone to the swamp zone, will provide older children with a variety of plants to identify and observe.

Children should search for plants that are rooted under water but with floating leaves. The area of water they cover can be indicated on the map.

Pond-dipping: observing animals

The children should look at the surface of the pond for evidence of animals such as pond skaters and whirligig beetles. Close observation of the surface of the pond may indicate the presence of fish or amphibians.

Children, in closely supervised groups, should take samples from the water. The first sweeps of the net should be made in open water with the whole of the net bag beneath the surface. The net should be pushed through the water for a distance of about two metres, making sure that the bottom mud is left undisturbed and that the net is lifted out quickly. White trays or basins that are half filled with water should be prepared to receive the catch. Children should observe closely to see water minibeasts darting about.

Children should collect animals from the water in specific areas. They should record what animals occur and observe what they are feeding on. The relationship between the location of certain species of animals and the presence of certain plants should also be investigated.

A few minutes is sufficient for dipping at the one location.

Food chains

Children should consider the questions

- What feeds on each of the pond organisms?
- What is the food for each pond organism?

The feeding relationships between organisms in a pond is simply represented using a food chain.

Children can establish different food chains in the pond by observing animals as they feed.

Food webs, which incorporate all the food chains in the pond community, may be explored by children in the senior classes who have a firm understanding of food chains.

Investigations with living things

Children's ideas about living things must be tested scientifically. These tests will be carefully controlled, and evidence will be gathered that will help the children to confirm or reject their initial ideas.

Investigative work with living things imposes ethical obligations on teachers and children. Care should be taken not to cause discomfort or distress to any animal being studied, either in its own habitat or in the classroom. Teachers should supervise closely the tests that children devise. Children may not always be able to predict what the outcomes will be for the creature or the length of time they need to carry out the investigation.

Small animals such as woodlice, snails and earthworms may be kept for short periods in the classroom. This work can help children to develop a sense of responsibility for animals and a sensitivity to and respect for the animal and its needs. Observing and investigating animals in the classroom will provide opportunities for children to develop scientific concepts of diversity, life cycles, feeding and behaviour.

Investigative work with small animals can concentrate on aspects of their behaviour such as

- food and feeding
- movement
- habitat and camouflage behaviour
- life cycles and reproduction.

The investigations outlined in the following pages focus on some aspects of the behaviour of small animals and can be undertaken without causing pain or distress to animals. It is recommended that children work in small groups under close supervision.

Observing behaviour: food and feeding

Children can be helped to discover the food preferences of the animals they are keeping in the classroom or observing outdoors. A food preference test involves offering the animal two or more foods to choose from. The different foods are placed in the container, and the children observe which the animal chooses. Children should be taught to maintain the welfare of the animal and should always include among the foods one that they know the animal will eat, so that it doesn't become hungry. The children should try to make their tests fair by offering the animals the same amount of different foods and making the food equally accessible. *Exemplar 18* outlines how a food preference test may be carried out in the classroom with children in first and second classes. Similar tests may be designed for other animals, such as ants, snails and worms.

Observing behaviour

Investigations of animal behaviour can be carried out using choice-chamber tests. These tests enable children to compare animals' responses to different conditions, such as wet and dry, light and dark. The choice-chamber test enables children to find out which factors influence the animal's choice of habitat.

During the test the animal is placed in a small container that is divided into smaller sections. Each chamber has a contrasting environment. These might be cool and warm, rough-surfaced and smooth-surfaced, or sand and leaves. The type of environments provided will depend on the variables the children have decided to test.

The animal then makes a choice between the environments, and the choice is recorded.

Choice-chamber tests can be carried out with small animals without any risk to their safety. The results of choice-chamber tests can be used by children to make the animal's classroom home more closely matched to its needs. If their tests indicate that woodlice favour dark conditions, then provision should be made for dark areas in the classroom vivarium. *Exemplar 19* illustrates how a choice-chamber test can be carried out in the classroom and the stages the children use to ensure fair testing and scientific working.

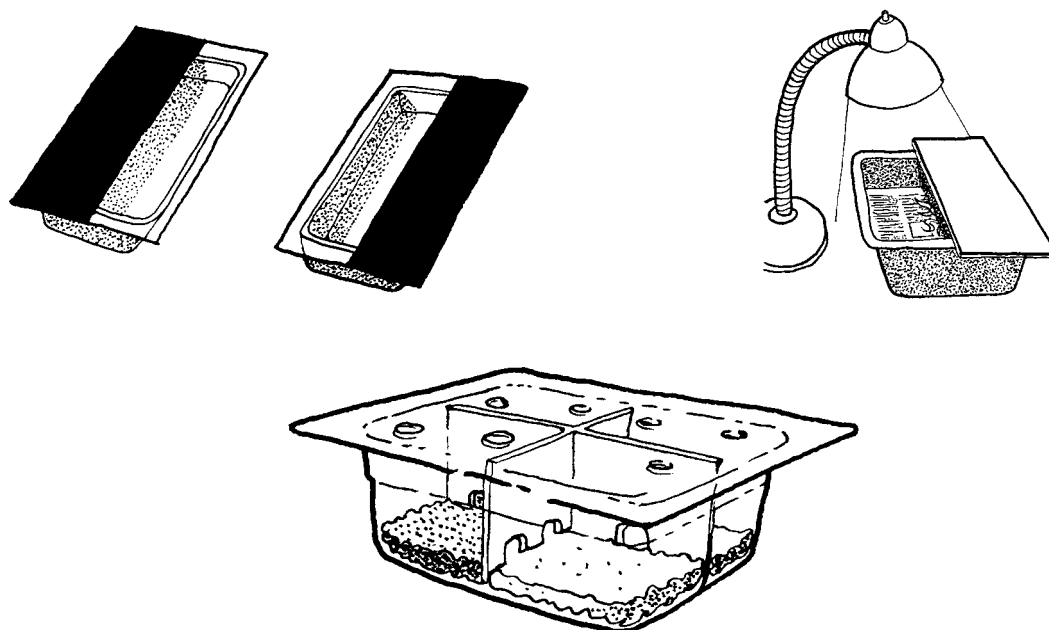

Exemplar 17

Useful techniques for collecting animals

A detailed study of a habitat may require the collection of animals. Animals collected during field trips should only be housed for short periods in suitable containers so that children can observe and measure them and make appropriate recordings.

Methods of collecting plants and animals

Animals should be collected using methods that protect their welfare. It is important that children are shown different ways of collecting and handling animals. They should return animals to their natural habitats after a short period.

Searching by hand

Children can search through soil and leaf litter to collect individual animals. Plastic spoons may be used to transfer some small, slow-moving animals to large containers, where they can be observed. In some cases small chunks of soil or leaf litter can be carried back to the classroom for observation. These samples should be transferred in small plastic bags.

A pooter may be used for collecting some small, fast-moving animals. Pooters may be designed by children using plastic ballpoint tubes, rubber tubing, a transparent plastic jar and some muslin.

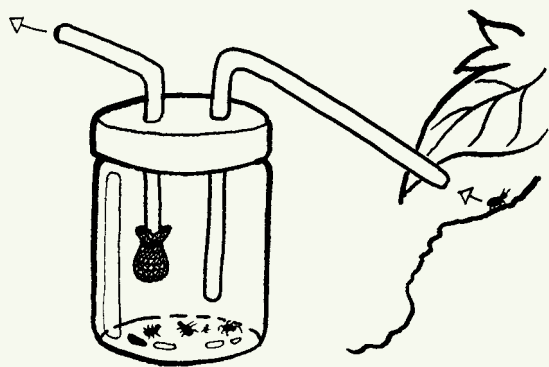

Older children may use a funnel mounted underneath a bulb to extract small animals, especially insects, from leaf litter or soil. The warmth and light from the bulb cause small organisms to move down through the layer of soil, through the sieve and down into the collecting jar.



Sweeping

A sweep net is used to catch insects by sweeping through grasses and tall vegetation. Sweep nets are also used for catching aquatic animals.

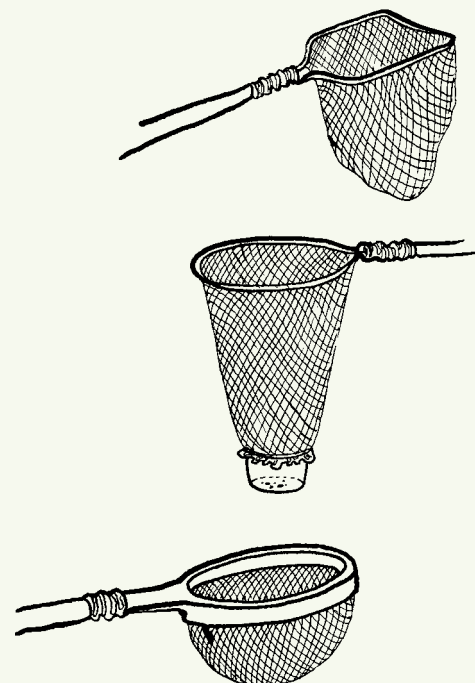

Shaking

A white sheet, cloth or brightly coloured umbrella is placed underneath a branch of a tree or shrubs. The plants are shaken with a ruler or stick. The small animals and insects fall onto the white surface and are visible to the children. The animals can then be scooped, using paintbrushes, plastic spoons or pooters, into containers for observation.



Sieving

An ordinary kitchen sieve can be used to collect aquatic animals from mud or sand. The mud can be collected in the sieve and washed several times with water. The mud will pass through the sieve, while the animals remain behind.

Baiting

A pitfall trap may be used to collect animals that are active on the surface of the ground, for example worms, slugs and woodlice. Some bait, such as meat, fruit or a sugar-based food, can be placed in the bottom of the jar. The trap is covered with a piece of bark raised up from the ground. This enables the animal to enter the trap and will keep the trap dry. The trap may be set by the children in the afternoon and checked the following morning. The animals can then be transferred to larger containers for identification.



Observations of the animals that live in concealed situations can be aided by placing a large piece of wood or stone in a shaded, damp area for a week. The children can then observe the animals that hide under the wood or stone every day, and records can be kept.

Flower heads

A polythene bag placed over a flower head and secured at the base is an effective method of collecting insects and other small animals that visit and feed on flower heads. However, a small polythene bag should be left in place for a limited time only and the animals then transferred to a transparent plastic container for observation.



Exemplar 18

Food and feeding

first and second classes

Identifying the problem to be solved

This group of children observed caterpillars for several weeks and recorded in a diary the food the caterpillars had eaten. The children fed the caterpillars every day, in the morning and the evening. Some children thought that the caterpillars liked to do most of their eating at night, and they wanted to test this idea. Their hypothesis was, 'Caterpillars eat more in the night than in the day.'

Planning the test

As the children planned the test they decided to use two cardboard boxes to house the caterpillars. They also discussed the type and amount of food to give to the caterpillars. They collected cabbage leaves of the same size and shape. Consideration was given to how best to measure the amount of food that the caterpillars would eat. The teacher suggested using squared graph paper to calculate the area of the leaves. The children decided to measure the leaves before and after they were fed to the caterpillars. The children then used the squared paper to make an outline drawing of each leaf. Each leaf outline and its matching leaf was numbered.

The children decided on when to conduct their test. They discussed feeding the caterpillars in the morning and in the evening. However, some children felt that feeding the caterpillars before they left school was not a fair test. They could not observe the animals that had eaten the leaves during the day or the night. The teacher encouraged them to think of ways to help make the caterpillars think it was night-time, and the children discussed how to make their container dark.

They decided to place one container in a dark cupboard and leave the other container in the light.

Controlling the variables: fair testing

The children were prompted to consider the fairness of the test. They decided to place one caterpillar in each box. Leaves of the same size and freshness were placed in the boxes. They placed one container in the dark and the other box in a bright area. The cupboard chosen to create the dark environment was near a radiator. The children felt that heat might make their caterpillars drowsy, so they chose a cupboard at the other side of the room.



The teacher asked the children to check that the test respected the animals' welfare. Caterpillars need airy containers, so children punched air holes in the sides of the containers. The children were satisfied that the conditions in both containers were the same. They placed one caterpillar in the container in the dark area. The other caterpillar was placed in the box in the light area. They decided to leave the caterpillars in the chosen locations until their lunch break.

Recording the results

The children recorded their results. They placed the leaves back in their own outline and drew around the shape left. They then counted the whole squares and part squares eaten by the caterpillars. Each part square was given the value of a half.

The results were recorded in a chart like this:

The amount of food eaten by our caterpillars

Caterpillar	Dark	Light
A	5 squares	
B		3 squares

Interpreting the results

The children felt that there was very little difference in the results they had obtained. They decided that they needed to get more results. The test was carried out on the following three days. The results indicated that these two caterpillars ate more in the dark.

However, after much class discussion the children decided that there was not enough evidence to show that their results could be applied to other caterpillars. They decided to repeat the test but to increase the number of caterpillars tested.

Exemplar 19

Choice-chamber tests with woodlice

all classes

Working with woodlice

Woodlice are good subjects for a wide range of investigations of animal behaviour. They are very easy to keep in the classroom and are very plentiful. Woodlice eat dead animal and plant materials.

Identifying the problem to be solved

These children had observed woodlice in their natural habitats: under rocks and stones, in leaf litter and in rotting wood. They created a vivarium in the classroom which incorporated a range of habitats, such as damp moss, a sloping layer of gravel, areas of damp and wet sand, stones, earth and leaves. The children wanted to test whether woodlice preferred damp or dry conditions. Their hypothesis was, 'Woodlice prefer damp places.'

Planning the test

The children decided to put the woodlice in a container that had a dry and a damp end. They made a simple choice-chamber from a plastic container and sand. A layer of dry sand was placed in the bottom of the container. They moistened one half of the sand tray with a water sprayer so that the sand was damp rather than wet.

Controlling variables: fair testing

The children needed to be sure that the woodlice would choose one end because of the dampness or the dryness. They discussed these questions to ensure that the test was fair:

- Are the damp and dry ends the same size?
- Is the temperature at both ends the same?
- Is the amount of sand at both ends the same?

The children then decided to test ten woodlice. They agreed to place the woodlice in the middle of the tray, as this was the best place for them to make a choice. They decided to leave the woodlice in the tray for five minutes.



Recording the results

The children recorded the number of woodlice in each part of the tray each minute. The results were then recorded in a table like this:

Time	Number of woodlice in damp end	Number of woodlice in dry end
1 minute	6	4
2 minutes	8	2
3 minutes	10	0
4 minutes	8	2
5 minutes	9	1

Interpreting the results

The children concluded that woodlice chose the damp end of the tray more often than the dry end. They decided to repeat the test several times to support their initial findings.

Investigating the processes of life in plants

A number of processes are common to all organisms but may be carried out in different ways. In the case of feeding and digestion, green plants produce their own food by photosynthesis. Plants use carbon dioxide, water and the sun's energy to make food and release oxygen as a by-product. Plants take up nutrients that are dissolved in water through their roots. As a result of these activities plants grow.

Plants as well as animals respire, that is, they use oxygen to burn up food. This process provides energy for the cells. Many animals have blood circulating in vessels throughout their bodies. Plants too have vessels in which food and nutrients move.

Plants can reproduce both sexually and asexually. The flower is the organ of sexual reproduction. Growing plants from cuttings is an example of asexual reproduction.

Plants, unlike animals, do not move from place to place, but they do move in response to light and other stimuli. Plants therefore display sensitivity, even though they have no sense organs.

Exemplar 20

Plant processes

infant classes

Initial problem: What helps seeds to grow? Do seeds sprout faster when it is warmer?

Background

Seeds need warmth, moisture and oxygen in order to germinate. At this level it is sufficient to examine one of these factors at a time. The connection between a seed and a plant may not be obvious to small children. They may not believe that seeds are alive.

Assessment: Among the techniques that may be used are

- teacher observation: willingness to try different ideas; willingness to work with others
- portfolio: annotated drawings of work
- concept maps.

Resources

Cress or some other fast-growing seeds; absorbent paper such as kitchen paper.

Starting points

observation

questioning

Development of lesson

experimenting

Follow-up activities

Germination

Let the children examine the seeds and note their texture, colour and size. Ask the children to consider:

Are these seeds alive?

What will happen to them if they are put on the window sill?

What will happen to them if they are left in the packet?

What will happen to them if they are placed in some water?

Explain to the children that a seed has a young, undeveloped baby plant inside it. Encourage the children to think of the factors that would help the plant to grow.

The following questions may prompt the children to offer suggestions:

- Do you think it might need water?
- Can you think of a way we could test to see if seeds need water?

Put the seeds on some kitchen paper on a dish and add some water.

The children can record what happens to the seeds after one or two days.

With the teacher's help, the children can consider the following problems:

Do seeds germinate or sprout more quickly in the classroom or in a fridge?

Do seeds germinate in the dark?

Exemplar 21

Plant processes

third and fourth classes

<p>Initial problem: How does water get from the roots to the tips of the leaves?</p> <p>Background</p> <p>Children should know that plant roots take up water. This lesson aims to help children become aware that there are vessels or veins inside a plant that can transport water and other substances.</p>	<p>Assessment: Among the techniques that may be used are</p> <ul style="list-style-type: none">• teacher observation: willingness to try different ideas; willingness to work with others• portfolio: annotated drawings of work• concept maps. <p>Resources</p> <p>Celery stalks with leaves attached, food colouring.</p>
---	---

<p>Starting points</p> <p><i>hypothesising</i></p> <p><i>experimenting</i></p> <p>Development of lesson</p> <p><i>observation</i></p> <p><i>hypothesising</i></p> <p><i>experimenting</i></p> <p>Follow-up activities</p>	<p>Plants have a transport system</p> <p>Ask the children to consider:</p> <p><i>What happens to plants if they cannot get water?</i></p> <p>The children should get two plants with roots. One plant should be placed with its roots in a jar of water, and the other plant should be placed upside-down with its roots in the air.</p> <p>The children should consider:</p> <ul style="list-style-type: none">• <i>What will happen to the plants? Why?</i>• <i>What does this tell you about what roots do?</i> <p>Ask children to consider how water travels from the roots to the tips of the leaves.</p> <p>Children should be asked to reflect on how blood travels through the body. Encourage them to consider whether there are special pathways inside a plant.</p> <p>Break a celery stalk. The children should observe stringlike structures (veins) coming out of the stalk.</p> <p>Ask children to consider:</p> <p><i>Can you think of a way to test if water travels in these veins?</i></p> <p>One method of testing this is to place a celery stalk in a jar of coloured water. The celery stalk should be examined after an hour.</p> <p>The children will find that the coloured water will have travelled only in the veins.</p> <p>Coloured plants could be produced by placing white flowers, for example carnations, in jars of coloured water. Predictions could be made about what would happen if the stems are split and placed simultaneously in jars of different-coloured water.</p>
---	--

Approaches to learning about light

Children in *infant* and *junior classes* will identify different light sources, explore the effects of light on materials, identify materials that are transparent or opaque, and experiment with shadows and reflections. Children will come to appreciate that they see objects and different colours because of light.

In the *middle* and *senior classes* pupils will distinguish between natural and artificial sources of light and will explore how white light is made up of many different colours. Children will investigate how light rays change direction as they pass through water and learn that this process is called refraction. Through designing and making activities pupils will develop a greater understanding of how mirrors and other shiny surfaces can change the direction of light and will explore how lenses are used to make things look bigger (magnified) or smaller.

Safety

When planning a unit of work on light the teacher will ensure that the children are aware of and adhere to the following safety procedures:

- children should not look at the sun or at very bright beams of light, such as projector beams
- plastic mirrors should be used for investigations, and children should avoid using glass mirrors
- pupils should never look at the sun through lenses

- children should be made aware of the dangers of sunburn.

Lessons on light energy present opportunities for teachers to instil in children the need to protect their eyes.

Introducing light and colour in the early years

In the *infant* and *junior classes* the concepts of light energy and colour should be integrated with other aspects of the curriculum.

Colour

Children in *junior* and *senior infants* should learn to identify and name different colours. Activities that develop an appreciation of light, colour and different shades of colour will involve the pupils in

- *collecting objects and materials for colour tables.* For instance, a 'red table' will include many items to represent the different shades of one colour that can be found. The children can arrange the items in order, from the darkest to the lightest. This will develop an awareness of variation within one colour
- *making collections of seasonal colours throughout the year.* Children can display different-coloured items found in the environment during the different seasons, such as the brown, gold, red and yellow colours of falling leaves and various fruits and seeds

- *exploring colours in the street, village or locality.* Children can go on ‘colour walks’ during the different seasons and observe
 - the colours that make the best signs
 - signs that can be seen at night
 - the colours that are associated with danger, for example in traffic lights and pedestrian crossings
 - the colours used for different elements of street furniture (litter bins, street lights, letter boxes, traffic lights and hydrant points)
 - colours that blend into the background and are hard to see.

The children might experiment and devise tests to establish the colours that are more visible in daylight, in the school yard and in the artificial light of the classroom. They might test the following ideas:

- Which colour of coat should the crossing warden wear?
- Which colours are the best for a road sign?

Exploring light and shadows

As well as developing an awareness of different colours and their use in the environment, it is important for children during the *infant* and *junior classes* to become aware of a variety of sources of light. Work on the topic of light and shadows will also increase their awareness that a variety of objects, such as torches, lamps and bulbs, give artificial light. The children will come to realise that some objects, such as their bodies, trees and cars, block out light and create shadows. Work on light and shadows can be undertaken indoors and outdoors.

Exemplar 22 illustrates an approach to the selection of content for a unit of work on light and shadows, possible methods of organisation and ideas for investigations and experiments.

Exploring light energy in the junior classes

In *first* and *second classes* children should recognise that the most important source of light energy for the Earth is the sun. Children should be encouraged to think about their own experiences of light and heat from the sun, for example sunburn, shadows, sundials and growing plants. This work should link with activities in the strand unit ‘Earth in space’ in the geography curriculum.

Pupils should know that light comes from different sources. The children can make a collection of these light sources so that they can be examined at first hand. They should be made aware that they can see objects because the light that shines on the object is reflected into their eyes. It might prove useful for children to imagine themselves in a dark cupboard. When the door is open, light enters and they are able to see. As the door is closed, light is excluded and their vision is reduced.

Exploring the effects of light and materials

This work should be an extension of the initial explorations of making shadows that were covered in the *infant classes*.

Children will explore how different materials can be sorted into sets—those that allow light through and those that do not. A variety of materials, such as glass, Cellophane, clear plastic, frosted glass, greaseproof paper, plastic sweet wrappers, paper and water, should be available to the children for experiment. Children in the *junior classes* may be able to identify two types of materials. Things through which light passes can be described as transparent; materials that do not allow light to pass through are opaque and will form shadows. Children in *third* and *fourth classes* may identify a third set of materials: translucent materials, such as frosted glass and waxed paper, which allow light to pass through but only in a blurred way. Once the children understand how

materials can be classified as transparent, translucent and opaque they should explore the school and its environs for samples of each type.

This strand unit provides many opportunities for designing and making with materials that are transparent, opaque and translucent. The exemplars in the science curriculum (pages 31 and 46) provide children with contexts within which the properties of materials used for making common objects such as lampshades, sunshades and glasshouses are examined. Children can discuss how to test the properties of each material. They might consider that the material used for glasshouses should be both transparent and waterproof. They might test different transparent materials to establish which one does not scratch easily. Such a material may be used to make a pair of sun shades. Samples of lampshades from children's homes may be examined and their properties assessed. The children can then design their own lampshade, using their own criteria and materials.

Investigating colours in sunlight— middle and senior classes

By the end of *fourth class* children should know that white light can be split into a range of colours, known as a spectrum. The children can use a slide projector and prism to cast a large spectrum on a wall. They can identify the colours and the order in which they appear on white paper or the screen. Other ways for children to see the spectrum are

- to place a plastic ruler in the sunlight and watch the spectrum as it appears on the ceiling or wall
- to blow bubbles
- to place a mirror in a shallow container of water in sunlight.

The white rays of sunlight fall on drops of rain, which act in a similar way as the prism to form a rainbow. Children can experiment to make a rainbow.

Mixing coloured light

The children should try mixing the primary colours of light. Three torches should be covered with red, blue and green filters and shone onto a white screen or piece of paper. The children will observe that different colour combinations occur. Green and blue light will combine to make cyan (blue-green); blue and red light make magenta (purple-red); and green and red light make yellow. Together the red, blue and green light beams should give white light, but only if the colours are pure and are projected at the same intensity. The process of mixing the primary colours of paint is different from mixing the primary colours of light; colour paints have a different set of primary colours.

Children should investigate what happens when they look at flowers, crayons and other coloured objects through different-coloured filters, and should record the results.

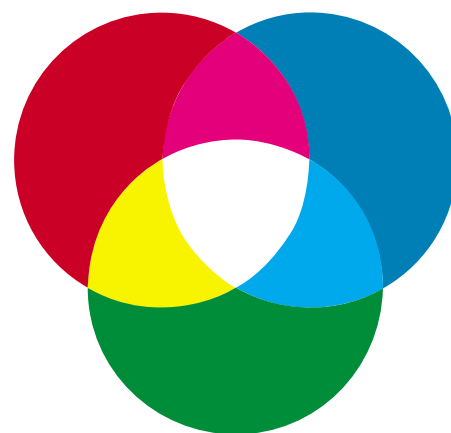

Exemplar 22

Light and shadows

infant and junior classes

Initial problem: What kinds of shadows can you make and see outdoors?

Background

Children explore how they can make shadows in the playground when their body blocks out the light. They should be aware that the source of light in this activity is the sun. They should investigate how their shadows can be changed by moving their bodies in different ways. Some children may develop an awareness that the position of the sun in the sky at different times of the day determines the length and direction of the shadows.

Assessment: Among the techniques that may be used are

- teacher observation: understanding of where the light is coming from; linking shadows and opaque objects; willingness to try different ideas; willingness to work with others
- portfolio: annotated drawings of work.

Starting points

Working in pairs, children stand in a sunny place in the school yard. Observations are made of different shadows. One child draws around the shadow with chalk.

Development of lesson

experimenting

The children are asked to explore:

- *How can you make a long shadow? short shadow?*
- *Can you and your partner make your shadows shake hands?*
- *How should you stand so that your shadow is in front of you? behind you?*
- *Can you find a way to hide your shadow?*
- *Where do you think your shadow will be if you stand facing your partner?*

Ask children to consider:

- *How do you think your shadow is made?*
- *What other things can be used to make shadows?*
- *Is your shadow the same shape as the shadow made by other people?*
- *Can you make shadows on a cloudy day?*
- *Can you make shadows at night-time?*

hypothesising

communicating

Children report back to the class group. They demonstrate how they made different shadows.

Concluding activities:

extension of lesson

Children should be given opportunities to make shadows at different times of the day. These activities can help them develop the idea that the shape and size of shadows change. Children's attention may be drawn to the fact that

- sometimes their shadows are longer or shorter
- sometimes the position of their shadows changes.

Encourage the children to measure the length of their shadows or the shadows of objects such as sticks and pencils.

Note: This theme may be developed as a lesson or as a unit of work.

Reflection of light from shiny surfaces

Children in the *middle* and *senior classes* will investigate that mirrors and other shiny surfaces can change the direction of light. A period of unstructured exploration should be planned so that the children can try bouncing sunlight on walls or playing 'light spot tag'. These activities should help children to realise that mirrors reflect light. Children can bounce a beam of light from a torch or projector off a mirror and onto another surface. Further investigations of the effects of bouncing light beams using two or more mirrors can be carried out. Designing and making a simple periscope using mirrors will support this work.

Through exploration, children will discover that mirrors reverse images. Games where they have to make the mirror image perform an action, such as blinking the left eye or touching the right ear, can be played. Work with mirrors will enable teachers to introduce the concept of symmetry. The children can be given half a picture, for example a butterfly, and asked to use a mirror to complete it. An investigation of the presence or absence of mirror symmetry in letters of the alphabet can also be undertaken. The children can first predict the letters that they consider to be symmetrical. They may come to conclude that some letters—X, O, I and H—have both horizontal and vertical lines of symmetry.

Materials and light: light refraction

Children should explore what happens to light as it travels through air, water and glass. A collection of transparent glass and plastic objects, such as bottles, glasses and fishbowls, should be available to the children. They will observe that when a pencil is placed in a glass of water it will appear broken at the boundary between the water and air. The children can predict how the pencil will appear in different containers. Compare how straight-sided and curved containers affect the appearance of the pencil.

Lenses

Children can explore how objects can be magnified using simple hand lenses. They should also observe how common objects such as drops of water, clear marbles and some water-filled containers can be used as magnifiers. They will discover that any clear, curved transparent material acts like a lens. Light rays that pass through the material are bent. This may cause objects viewed through the lens to appear magnified or reduced. The magnifying power of two different improvised lenses, such as a narrow jar of water and a wide jar of water, can be compared.

Approaches to learning about sound

Sounds in the environment

In the *infant* and *junior classes* children should explore sounds in their environment and be able to distinguish and describe them. Activities to encourage children to listen to sounds will include guessing games in which they try to identify the sounds made by hidden objects in a container. Children can go on a 'sound walk' around the school and school environs. They can record the sounds they hear through pictorial records or by making their own audio recordings.

Sound and music

It will be important that the work on sound be linked to the music curriculum. Children should develop listening skills and distinguish between loud and soft, high and low sounds. Access to a range of different musical instruments can help children to consider how sounds are made. They should explore the different ways of playing musical instruments, by plucking, tapping, blowing and shaking. Children should also make their own instruments from reclaimable domestic waste.

Sound and vibrations

Sound is made when something vibrates. Children should find different things that vibrate, for example rulers, rubber bands, metal hangers or the spokes of a bicycle wheel. They can be challenged to discover the factors affecting the sound produced by a rubber band or guitar strings. They will discover that the thickness, length and tension of the rubber band (or string) will affect the pitch of the note produced. They may discover that higher sounds can be made with thin, short strings and that lower sounds can be made with heavy or longer strings.

Materials that transmit sound

In the *middle* and *senior classes* children will develop their understanding of the nature and properties of sound. Many children think that sound travels only through air. They will be guided to discover that sound can travel through solid substances, gases and liquids. They can make string telephones to demonstrate that sound travels through solids. The children can discover that liquids such as water transmit sound by listening to the fizzing sound of an Alka-Seltzer tablet that is placed in water. Other materials, such as wooden dowelling, metal rods, plastic and copper piping, can be investigated for their effectiveness in transmitting sound.

Links to environmental issues

Work on the nature of sound can lead to the discussion of noise pollution. The children can discuss the issues of loud sounds that are unpleasant and may cause damage to ears and hearing. An audit of sounds in the locality can be carried out. Children can investigate ways of controlling loud sounds. They should explore ways of muffling sounds, for example wrapping a clock, radio or 'talking' toy in different materials, such as pieces of foam, fabric, paper, cotton wool and polystyrene. Links to previous activities can be made. Children will know that sound travels through solid objects better than through air. They will discover that materials with air holes (porous materials) absorb sounds and will make better sound insulators than materials such as metal or wood, which reflect sounds.

Exemplars

Exemplar 23 outlines an activity that pupils can undertake to explore how the tension, thickness and length of a rubber band can affect its pitch.

Exemplar 24 illustrates how children can compare and measure the effectiveness of different materials in insulating against sounds.

Exemplar 23

Sound

third and fourth classes

<p>Initial problem: Can you make a banjo from rubber bands?</p> <p>Background The tightness, thickness and length of the rubber band will affect the pitch. Long, thick rubber bands produce low sounds. Thin, short rubber bands produce higher sounds.</p>	<p>Assessment: Among the techniques that may be used are</p> <ul style="list-style-type: none"> • teacher observation: willingness to try different ideas; willingness to work with others • portfolio: annotated drawings of work • concept maps. <p>Resources Rubber bands of varying length and thickness, a shoebox lid or biscuit tin lid.</p>
--	--

<p>Starting points</p> <p>experimenting</p> <p>observing</p> <p>comparing</p> <p>experimenting</p> <p>Development of lesson</p> <p>hypothesising</p> <p>predicting</p> <p>experimenting</p> <p>fair testing</p> <p>inferring</p>	<p>Children should consider the problem:</p> <p><i>Will stretching (tension) the rubber band affect the sound produced?</i></p> <p>Children stretch rubber bands of different lengths around the shoebox lid. They should ensure that the rubber bands are of equal thickness and are placed evenly across the lid.</p> <p>The children pluck the bands with their fingers or with a pencil.</p> <p>Compare the sounds produced.</p> <ul style="list-style-type: none"> • <i>Which bands make the lower sounds?</i> <p>Consider:</p> <ul style="list-style-type: none"> • <i>How does tightening a short band affect the sound produced?</i> • <i>Is the sound higher or lower than the sound produced by the other bands?</i> <p>Children consider the problem:</p> <ul style="list-style-type: none"> • <i>Does the thickness of the rubber band make a difference to the sound?</i> <p>Children undertake a similar experiment, but this time the variable is thickness. Children should try thick and thin bands.</p> <p>Predict the bands that will make the low and high sounds.</p> <p>Compare the sounds made by the different bands.</p> <ul style="list-style-type: none"> • <i>Which bands, thick or thin, make the higher sounds?</i> <p>Children should now combine variables and compare the sounds produced by a long thin band, a long thick band, a short thick band and a short thin band.</p> <p>The children should use their combination of bands to</p> <ul style="list-style-type: none"> • <i>explore different pitches that they will produce</i> • <i>play some simple songs or nursery rhymes.</i> <p>Children should consider:</p> <ul style="list-style-type: none"> • <i>Which bands make the lower sounds?</i> • <i>Which bands make the higher sounds?</i> • <i>How can you change the sound produced by a long thick band?</i>
--	---

Exemplar 24

Sound insulators

fifth and sixth classes

<p>Initial problem: Which materials are good insulators of sound?</p> <p>Background Some materials absorb sounds. These are called insulators. Some materials are better insulators than others. Hard surfaces reflect sound.</p>	<p>Assessment: Among the techniques that may be used are</p> <ul style="list-style-type: none"> • teacher observation: willingness to try different ideas; willingness to work with others • portfolio: annotated drawings of work • concept maps. <p>Resources Alarm clock, newspaper, cotton wool, tinfoil, carpet pieces, a shoebox, fabric.</p>
---	--

<p>Starting points</p> <p>observing</p> <p>recording</p> <p>Development of Lesson</p> <p>predicting</p> <p>experimenting</p> <p>measuring</p> <p>recording</p> <p>hypothesising</p> <p>Extension activities</p>	<p>The children will need an alarm clock. Set the clock to ring within a few minutes. Place the clock inside the box and put on the lid. When the clock rings the children should measure how far away they can hear the ringing. The children make a record of the distance.</p> <p>Children consider which materials will make good insulators (muffle sounds). Children should select the materials that they wish to test. Make predictions about the materials that they think will make the best insulators of sound. The children should try to make the test fair. Wrap the clock in newspaper, carpet, fabric or cotton wool. Place the clock in the box as before and replace the lid. The children record the distance at which they can hear the sound. Compare this distance with the measurement taken in the initial activity. Children should test the different materials in turn. Record and compare the distance with the other distances. Children should consider:</p> <ul style="list-style-type: none"> • <i>Is it possible not to hear any ringing at all?</i> <p>Children should consider using a combination of materials. Arrange the materials inside the shoebox in different ways. Further problems may arise:</p> <ul style="list-style-type: none"> • <i>If the clock is well insulated, how will they know if it is ringing?</i> <p>The children should be encouraged to think of ways of solving this problem.</p> <p>Children can consider the materials that would make the best insulators of sound in houses. Materials, such as foam and polystyrene, that are placed in cavity walls can be tested.</p>
--	---

Approaches to learning about electricity and magnetism

Mains electricity should never be used during science investigations.

Safety issues

Work on the topic of electricity and magnetism will provide opportunities for children to learn about the safe use of electricity. It is important that children realise the dangers of mains electricity and become aware of and discuss safety issues associated with the use of mains electricity and electrical appliances. Batteries should be used for activities based on electric current. Mains electricity should never be used during science investigations.

The children should be aware of the following safety considerations:

- the dangers of touching the bare metal of a plug or a switch especially when hands are wet
- the importance of not using electrical appliances without adult supervision
- the dangers associated with flying kites or using fishing rods near overhead wires
- the risks attached to playing near electricity sub-stations.

Equipment

The types of batteries required for work on electricity are shown below. The battery voltage suggested in the exemplars that follow is by way of example only. Other batteries could be substituted. However, the battery voltage should be about the same as that specified on the bulb, for example:

Battery	Bulb
1.5 V	1.25 V
3 V	2.5 V
4.5 V	3.5 V
6 V	6 V

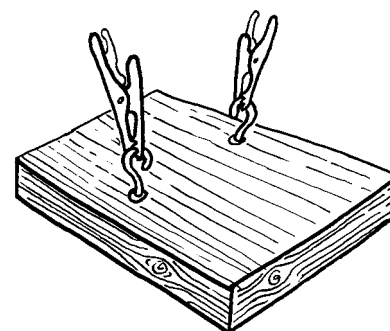
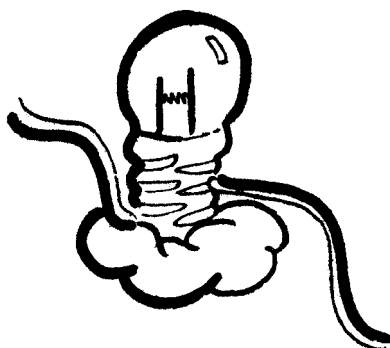
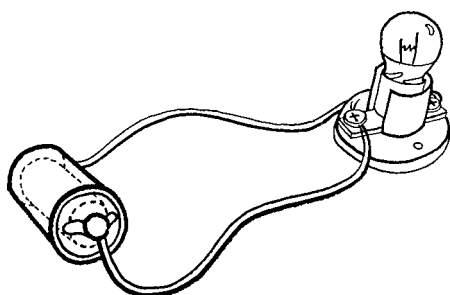
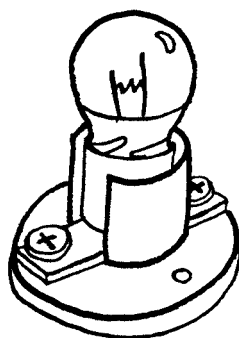
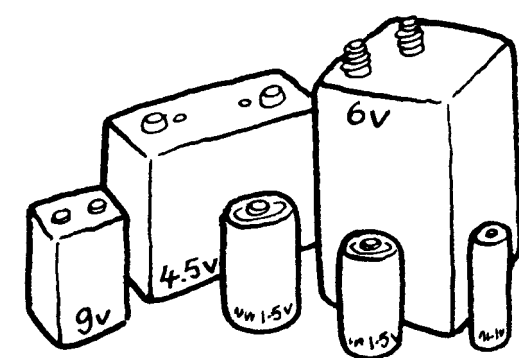

Commercial bulbholders can be obtained through science suppliers. However, improvised bulbholders can be made by the children, using

- Plasticine
- clothes pegs
- plastic film cylinders. Punch a hole in each end of a round film holder (the cylinder used to contain 35 mm film). Insert a brass paper fastener and press it open. Attach the wires to the brass paper fastener. An R6 battery should fit exactly inside the holder. The circuit is made as the terminals of the battery touch the brass paper fasteners.

Activities on electromagnetism may require the use of nails. Teachers should ensure that only blunt nails are used; hammering the tip of a nail will achieve a blunt finish.

Crocodile clips can be used to make connections in circuits. These are particularly helpful for younger children, who may not have the manual dexterity to use a screwdriver to connect leads. It may be necessary to mount bulbholders onto wooden blocks and connect the crocodile clips to screw eyes.

Safety and care of equipment

Work on electricity at all levels will involve the use of batteries. The following safety procedures should be observed

- batteries must not be cut open
- batteries should be disposed of in a safe manner. There may be a battery recycling depot in the locality
- rechargeable batteries should not be used for investigations
- leads, composed of lengths of insulated wire, will be necessary for making circuits. The teacher or a specially designated adult can strip the plastic covering from the leads using wire cutters and strippers or a sharp scissors. Children should never undertake this task.

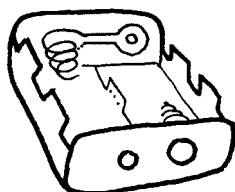
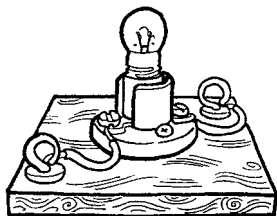
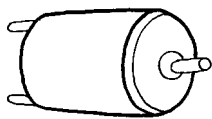
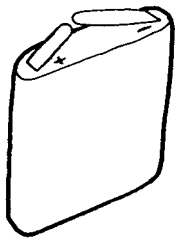
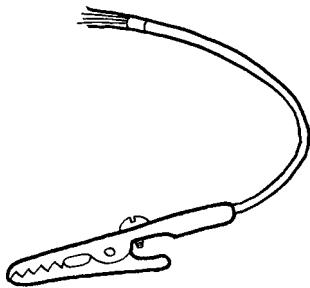
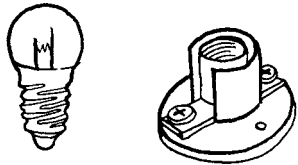

Electricity

Static electricity

Static electricity occurs when an electric charge builds up on an object. This build-up can happen by rubbing one material against another. Electrons are rubbed off one of the materials, which then becomes positively charged, while the other material, which gains the electrons, becomes negatively charged. The two materials then attract each other, for example rubbing a balloon against a woollen jumper.

When a charged object is connected to another object or to the Earth, electrons flow between the objects. This can be experienced as a slight shock by a person when a car door is touched after moving against upholstered seats or as the crackling sound of hair when it is combed after being washed and dried. *Exemplar 25* illustrates how a lesson on static electricity may be structured for *first* and *second classes*.

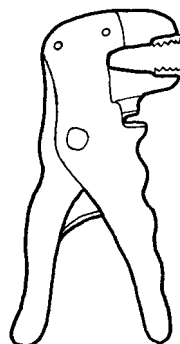

Electrical energy

Starting from children's ideas

It is important to recognise that children are likely to have prior ideas about electricity, which can be explored and challenged by posing questions such as:

What sort of things use electricity?

Children make two lists or two collections of things that run on mains electricity and those that are battery-powered. Some objects, such as radios, computers and hand drills, may come under both headings.

How does electricity get to where it is needed?

Children can draw pictures showing the electrical supply to their house or school. Older children can make annotated drawings of how electricity gets to a bulb from a battery or from the mains supply to an electrical appliance.

It is likely that children will not be aware that a full circuit is needed for electricity to flow. Their own experience will suggest that only one wire or cable is required: for example, the children will observe that only one wire is leading to every electrical device in the house. It will be important that children have plenty of opportunities to establish the idea of a full circuit.

Exemplar 25

Static electricity

first and second classes

Initial problem: Why does my hair crackle when I comb it? When I rub a plastic pen through my hair, can I then use it to pick up pieces of paper?

Background

You can get static electricity by rubbing different objects together. Children will learn that like charges repel and unlike charges attract each other.

Assessment: Among the techniques that may be used are

- teacher observation: willingness to try different ideas; willingness to work with others
- portfolio: annotated drawings of work.

Resources

Balloons, woollen jumper, paper, pieces of carpet, pieces of nylon, pen, plastic comb, string.

Starting points

investigating

observing

Ask the children to rub a plastic pen through their hair. They can then use the pen to pick up small pieces of paper. Ask the children to consider:

- *How many pieces of paper were attracted to the pen?*
- *How many times do you need to rub the pen through your hair to pick up the pieces?*

Children can watch as one member of the group combs his/her hair quickly with a plastic comb. Does the hair seem to stand on end?

The children are making static electricity.

Development of lesson

questioning

experimenting

Rub an inflated balloon several times with a woollen jumper. Test to see if the balloon has static electricity. The children may suggest, based on their previous experience, that the balloon might pick up some pieces of tissue or that it might make their hair stand on end. They should also try out their own ideas.

This activity may be developed to test the materials that will produce static electricity.

Children can make a collection of different materials: woollen objects, samples of nylon, cotton and carpet. They should reflect on how to make this a fair test:

- *Will we use the same balloon in each test?*
- *If we use a different balloon for each test should all the balloons be the same size and shape?*
- *Will we use materials of the same size for each test?*
- *How many times will we rub the balloon with each piece of material?*

Children test the materials and record their results in sets:

- *Make a set of things that produce static electricity*
- *Make a set of things that do not produce static electricity.*

fair testing

recording

Extension of lesson: follow-up activities

The children can explore these questions:

- *What happens when two balloons with static electricity are placed beside each other?*
- *What happens when a balloon with static electricity is placed near flowing water?*
- *Which type of hair (curly, straight, long, short, newly washed and dried) produces static electricity?*
- *How can I use static electricity to separate pepper and salt?*

Story to read

The children can read or listen to a story about Benjamin Franklin.

Note: This theme may be developed as a lesson or as a unit of work.

Current electricity

In the *middle* and *senior classes* children should have opportunities to construct circuits with batteries, wires, and components such as bulbs, switches and motors. They will discover how to make bulbs light and make switches and motors work. Investigations with electricity will provide many opportunities for activities with a technological focus. Children will design and make a variety of their own switches, using different materials and for different purposes.

Exemplar 26 describes how children in *third* and *fourth classes* can make a simple circuit. This activity is also suitable for older children who are starting work on this topic.

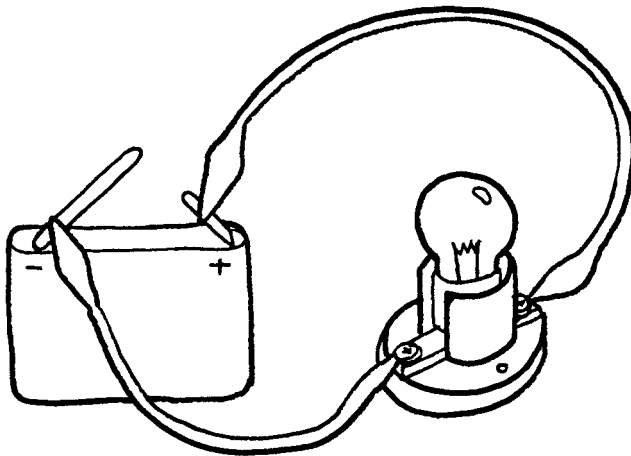

Making circuits with two or more bulbs

Children in the *senior classes* will be guided to investigate how to make circuits using series and parallel wiring. In a series circuit the electricity flows through each bulb or component. When one bulb is removed the circuit is broken and all the lights go out. Children may discover that the more bulbs that are added to the series circuit the dimmer the light from each bulb becomes.

In a parallel circuit each bulb has its own circuit to the battery. If one of the bulbs in a parallel circuit is removed, no other light or component will be affected. When bulbs are in a parallel circuit each of the bulbs receives the same flow of electricity from the battery. Therefore the bulbs are equally bright.

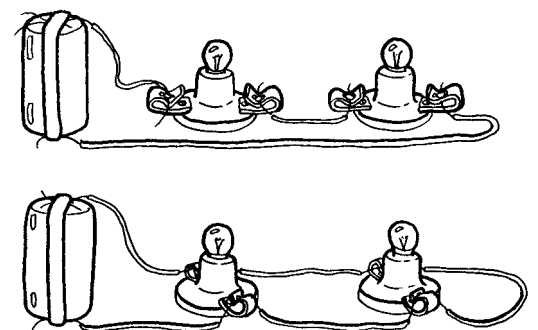

When children have succeeded in lighting bulbs in series and parallel circuits they should be prompted to investigate the following questions:

Which circuit produces the brightest lights?

What happens if one bulb is removed from each circuit?

How long does a battery last in a series circuit and in a parallel circuit?

Conductors, insulators and switches

Conductors are materials that allow electric current to pass through them. Metals are the best conductors of electricity and are used for electric wires. Rubber, plastic, glass, cloth and other non-metallic materials are poor conductors. This explains why appliance plugs and electric wires are covered with rubber or plastic. *Exemplar 27* is an example of an investigation based on conductors and insulators.

Children should investigate materials that allow electricity to pass through them. They should make simple on-off switches. Older children can make two-way switches.

Electromagnetism

In the *senior classes* children will explore how electricity and magnetism work together. They will discover that when a current passes through a coil of wire, the coil acts like a magnet. *Exemplar 28* illustrates how a lesson on electromagnetism may be structured and how children can investigate the factors that affect the strength of an electromagnet.

Exemplar 26

Making a circuit

third and fourth classes

Initial problem: How can I make the bulb light?

Background

Electricity flows when there is a complete circuit. Children will discover that there are several ways to get a bulb to light. They should note that the battery has two terminals, the metal cap at the top and at the base. The children will succeed in lighting the bulb if one wire travels from the terminal to the side of the bulb and the other wire goes from the base of the bulb to the second terminal.

When two or more batteries are used in a circuit the brightness of the bulb is increased. The electrical energy in the circuit increases as the voltage increases. The batteries must be connected in the correct way in a torch: the positive

terminal of one battery should touch the negative terminal of the other.

Assessment: Among the techniques that may be used are

- teacher observation: willingness to try different ideas; willingness to work with others
- portfolio: annotated drawings of work
- concept maps.

Resources

A battery, bulb and two strands of wire. The wire should be bared at the ends.

Starting points

experimenting

predicting

Development of lesson

experimenting

recording

Extension of lesson: follow-up activities

experimenting

Structured exploration

In pairs the children try to light the bulb using two wires and a battery.

Encourage the children to predict what will happen before they construct their circuit.

- *How many ways can you light the bulb?*

Encourage children to connect the wires in different ways and at different points in the bulb or battery.

Children should make a record of each circuit that they construct and the results obtained.

The following questions may prompt children to further their investigations:

- *How many ways can you light a bulb using only one wire and a battery?*
- *How many ways can you light two bulbs with two wires?*
- *How many ways can you light two bulbs with three or four wires?*

When the children have succeeded in getting the bulb to light in different ways they should then progress to using a bulbholder and be asked to repeat the activity with the bulb in the bulbholder.

It will be necessary to show pupils how to attach the wires correctly to the bulbholder.

Encourage children to think about:

- *How many ways can you find to make the bulb go out?*

The children might later begin to experiment using two batteries.

- *Can you make a circuit with two batteries, two wires and one bulb?*

If the children are using two 1.5 V batteries, a 2.5 V bulb can be used. Question the children:

- *Is the bulb brighter or dimmer when two batteries are used?*
- *How were the batteries arranged so that the bulb would light?*

Exemplar 27

Conductors and insulators

third to sixth classes

Identifying the problem to be solved

This group of children wanted to find out which materials would make the best switch in their circuit. The children suggested several hypotheses:

I think that all metals can be made into switches.

I think that only plastic can be used, because all the switches at home and school are plastic.

I think that only shiny metals can be used.

Planning the test

The children made a collection of different materials—iron, copper, aluminium, coins, plastic spoons, paper, paper clips, rulers, tinfoil, fabric, coat hangers, rubber bands, pencil sharpener and nails.

They then predicted which materials would allow electricity to pass through them. Their predictions were recorded by making two sets

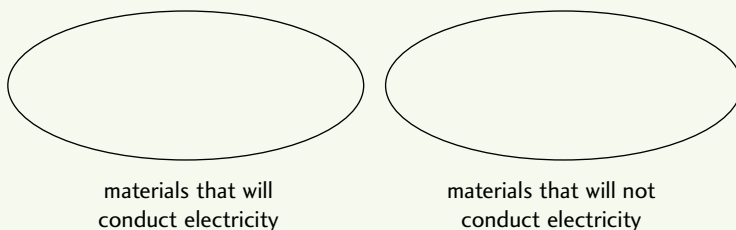

They decided that they would make a circuit using a bulb, battery and wires. A gap would be left in the circuit. Each material would be placed in the gap and tested.

Controlling the variables: fair testing

The children were prompted to consider the fairness of the test. They decided that they would test materials of the same size and thickness.

They placed each of the chosen materials in the circuit. They observed whether the material allowed electricity to pass through.

Recording the results

The children recorded their results. They compared the predictions that were made at the start of the investigation with their results. The teacher prompted them to make sets of conductors and insulators. The children concluded that, in

general, metal is a good conductor of electricity, whereas fabric, paper and plastic are good insulators.

Interpreting the results

The children felt that they had identified a large group of materials that could be used as switches in their circuits but that they had not identified the best metal for making a switch. They decided that they would repeat the test using only metals. They refined the idea to be tested:

Which metal is the best conductor of electricity?

After re-testing, the children identified a small group of objects that they considered to be good conductors of electricity. These included paper clips and nails.

Further ideas for testing were generated. Some children suggested that a metal conductor would be affected by rust, paint, dirt or grease. Children decided to use the paper clips and nails and to repeat the experiments. They had to ensure that the test was fair, so rusty nails, greasy nails, clean nails, dirty nails and painted nails were tested.

The children concluded that metals conduct electricity if they are clean and shiny.



Exemplar 28

Electromagnetism

fifth and sixth classes

<p>Initial problem: How can I make an electromagnet?</p> <p>Background Most of the objects attracted to the electromagnet will fall when the electromagnet is disconnected from the battery. Children will discover that the more turns of wire in the coil, and the more batteries used, the stronger the magnetic field that is produced.</p>	<p>Assessment: Among the techniques that may be used are</p> <ul style="list-style-type: none">• teacher observation: willingness to try different ideas; willingness to work with others• portfolio: annotated drawings of work• concept maps. <p>Resources Batteries (1.5 V, 4.5 V, 6 V), bell wire of different lengths, nails, paper clips. The wire should be insulated with plastic but bared at the ends.</p>
---	--

<p>Starting points</p> <p>experimenting</p> <p>observing</p> <p>Development of lesson</p> <p>investigating and experimenting</p> <p>fair testing</p> <p>Extension activities</p>	<p>Teacher demonstrates how to make an electromagnet. A large nail that has not been magnetised will be required. The wire (1 metre) is wrapped around the nail. Leave 15 cm of wire free at both ends. Connect the bare ends of the wire to a battery.</p> <p>The children can test to see how many paper clips the electromagnet picks up. Record the results.</p> <ul style="list-style-type: none">• <i>Which end of the electromagnet will pick up more clips?</i>• <i>What happens to the paper clips when the electromagnet is disconnected from the battery?</i>• <i>Can an electromagnet attract objects that an ordinary magnet cannot attract?</i>• <i>What happens if you substitute a pencil for the nail?</i> <p>Children can observe the effects on a compass that is placed near the electromagnet.</p> <p>Prompt the children to think of ways to make the electromagnet stronger. The following questions may help them to develop their ideas: What affects the strength of an electromagnet? Is it the</p> <ul style="list-style-type: none">• <i>length of the nail?</i>• <i>thickness of the nail?</i>• <i>length of the wire?</i>• <i>thickness of the wire?</i>• <i>type of wire?</i>• <i>number of times the wire is wrapped around the nail?</i>• <i>number of batteries used?</i>• <i>voltage of the batteries?</i> <p>Children should work in groups to investigate the problem. Remind them that only one variable should be tested at a time. If the length of nail used is being tested, then the children should ensure that all other factors (the length of wire, the number of turns of wire in the coil, the voltage of the battery) should remain constant. The strength of the electromagnet can be assessed by the number of paper clips it picks up.</p> <p>Children can make an electric buzzer or doorbell. Note: This theme may be developed as a lesson or as a unit of work.</p>
---	---

Magnetism

Children will discover that magnets exert a force that can cause some things to move. We call this pull magnetism. In the *infant* and *junior classes* children will notice that some objects move towards the magnet before it touches them.

They will also discover that some materials are not attracted to magnets. In the junior classes children will sort materials into sets: a set of magnetic objects and a set of non-magnetic objects. Children will discover that the magnet attracts only metallic objects. However, they will notice that not all metallic objects are magnetic. Children should observe that the pull of a magnet can pass through certain materials, such as water, glass, plastic and paper.

In a magnet the force of attraction is concentrated at two points, known as the poles. Children can experiment to discover that magnets attract and repel other magnets. Similar or 'like' poles repel each other, and different or 'unlike' poles attract each other. The north-seeking pole of a magnet is referred to as the north pole, and the south-seeking pole is referred to as the south pole. Children will discover that they can make a magnet by stroking a steel sewing needle with the pole of a magnet. When a magnet can move freely (sewing needle placed on a cork in a basin of water) it will come to rest with its north pole pointing towards magnetic north.

Children can observe the pattern of a magnetic field of one or two magnets by using iron filings. Place the filings in a transparent plastic box and place the magnet on the box.

Exemplar 29 illustrates how this topic may be developed in the *junior classes*.

Safety and care of equipment

Magnets need to be stored carefully to preserve their magnetism. They should be stored with their keepers. The keeper is the small metal bar that should be placed across the poles of a magnet. If magnets are stored in pairs, unlike poles should be put together in the box.

Heating, hammering or repeatedly dropping magnets will cause them to lose their magnetic properties.

Exemplar 29

Magnetism

first and second classes

Initial problem: Which is the best magnet?

Background

The attraction that magnets exert on paper clips is strongest at the ends or poles of the magnet. Stronger magnets will exert a pull from a longer distance.

If a pupil suspends paper clips in a line (touching, not linked) they will discover that a paper clip hanging from a magnet turns into a magnet itself and can attract another paper clip, so that a chain is formed. The stronger the magnet the longer the chain that can be formed.

Children should be able to conclude that the strength of the magnet is independent of size, colour and shape and dependent on the type of metal from which the magnet is made.

Assessment: among the techniques that may be used are

- teacher observation: willingness to try different ideas; willingness to work with others
- portfolio: annotated drawings of work
- concept maps.

Resources

A range of different-shaped magnets—ring, bar, horseshoe; paper clips, nails.

Starting points

experimenting

observing

experimenting

Development of lesson

hypothesising

predicting

investigating and

experimenting

Initially the children can investigate the following problem:

- *How many paper clips can a magnet pick up if it is lowered into a pile of paper clips?*

Encourage the children to test the different magnets. Observations should be made of

- *the number of paper clips attracted to the magnet*
- *the parts of the magnets that pick up the paper clips*
- *the parts of the magnets that do not pick up the paper clips*

The children can then test to establish the strongest part of the magnet.

Encourage the children to test

- *the number of paper clips that can be suspended in one line (touching but not linked) from different parts of the magnet*
- *the number of paper clips picked up by each pole.*

Children should discover that the strongest parts of the magnets are at the ends or the poles.

Set children the problem:

- *Which magnet is the best?*

The children can be challenged to think of the factors that might make a difference to the strength of the magnet. Their ideas might include the colour, size, shape, weight or material from which the magnet is made. The children's predictions should then be recorded.

Children can discuss how they will compare or measure the strengths of the different magnets. Some ideas that may be suggested include:

- *the number of nails that can be suspended from each magnet*
- *the number of nails that a magnet will pick up from a heap*
- *the weight that each magnet will carry*
- *the distance from a nail at which a magnet can be held so that it can pick up the nail.*

The teacher and children discuss how to make this a fair test. The only variable to be changed is the magnet being tested.

The children record the results using simple pictorial graphs.

Approaches to learning about forces

Scientists describe force as a push or a pull. Pushes and pulls can get things to move. They can also speed up or stop a moving object and change its shape and the direction in which it is moving.

Forces cannot be seen and sometimes cannot be felt. Consequently, it is not surprising that many children and adults do not think about forces.

Practical experiences that help children to become familiar with the terms ‘pushing’, ‘pulling’, ‘floating’ and ‘sinking’ would be a useful starting point for work on forces. These experiences will provide the basis for the work in the *middle and senior classes*, when children will develop an understanding of forces and their effects. At all stages it will be important that children can relate their science investigations to everyday experiences; they will be aware that force is applied when they pull the top from a pen, open and close doors, roll a marble or push a supermarket trolley.

Safety

Care should be taken during work on forces, because of the risk of injury resulting from moving objects.

Exemplar 30 illustrates an approach to the teaching of the topic of floating and sinking in *infant and junior classes*.

Suggestions are offered for the organisation of the lesson and for the employment of strategies for the development of scientific skills.

Exemplar 31 describes how a unit of work on pushes and pulls can be structured for *infant classes*.

Exemplar 30

Floating and sinking

infant and junior classes

<p>Initial problem: Why do some things sink and some float?</p> <p>Background Children may first assume from their activities that objects float because they are light. They may expect heavy objects to sink and light ones to float. Careful selection of objects may help them to develop the idea that shape matters as well.</p> <p>Through informal activities children should experience the pushing force of water as they try to sink a floating object such as a beachball.</p>	<p>Assessment: Suitable techniques include</p> <ul style="list-style-type: none"> • teacher observation: willingness to try different ideas; willingness to work with others • portfolio: annotated drawings of work • concept maps. <p>Resources Containers for water, such as an aquarium or a baby bath; a variety of common objects of different sizes, shape and weights, for example blocks of wood, wooden spoons, apples, plastic spoons, toys; boats, balloons, squeeze bottles, sponges.</p>
--	---

<p>Starting points</p> <p>observation</p> <p>Development of lesson</p> <p>predicting</p> <p>experimenting</p> <p>sorting and grouping</p> <p>experimenting</p> <p>communicating</p> <p>Extension of lesson: follow-up activities</p>	<p>Objects made from different materials and of different size and weight are provided. Some children may assume that objects float or sink because they are light or heavy. Encourage them to test their ideas.</p> <ul style="list-style-type: none"> • <i>Which things will sink? Test to find out.</i> • <i>Can you make a guess what will happen to this?</i> <p>The teacher introduces new objects into the set.</p> <ul style="list-style-type: none"> • <i>Which are the heavy things?</i> • <i>What will happen when you put something heavy into the water?</i> • <i>Do all heavy things sink? Try them. Now what do you think?</i> • <i>Do all the metal things sink? Try them.</i> • <i>Will all the sinkers be made from the same material?</i> <p>Children should investigate what happens when different objects made from the same material are placed in water.</p> <ul style="list-style-type: none"> • <i>What are the things that float made from?</i> • <i>What wooden things float/sink?</i> • <i>Are the wooden floaters big or small?</i> • <i>Are the wooden floaters light or heavy?</i> • <i>Are the plastic floaters big or small, heavy or light?</i> • <i>Can you find any more wooden/plastic things that can float?</i> • <i>Can you make the floaters sink?</i> • <i>Can you think of different ways of making them sink?</i> <p>Children can record results by making sets of floaters, for example a set of plastic floaters and a set of wooden floaters.</p> <p>Children can explore whether shape is an important feature in floating objects. They should try to make materials such as Plasticine or modelling clay float by hollowing them out.</p> <p>They can apply their knowledge of the factors that determine whether things float (the material, the size and weight) when they make boats or rafts.</p> <p>Note: This theme may be developed as a lesson or as a unit of work.</p>
--	--

Exemplar 31

Approaches to learning about forces

infant and junior classes

<p>Initial problem: Why do things move?</p> <p>Background When we move things we push or pull them. Squeezing, stretching and twisting are all types of pushes and pulls. A big push or pull will have a greater effect on the movement of an object than a small push or pull.</p>	<p>Assessment: Suitable techniques include</p> <ul style="list-style-type: none"> • teacher observation: willingness to try different ideas; willingness to work with others • portfolio: annotated drawings of work • concept maps. <p>Resources Lesson 1: Collection of moving things in the classroom; pencil case with a zip, toy telephone with a circular dial, yo-yo; toys, cars, pram, shopping trolley, clocks, egg beaters, spinning tops, tricycle or bicycle. Lesson 2: Sponge, cloth, rubber bands, balloon, squeezey bottles, ball.</p>
---	--

	Lesson 1: Pushing and pulling	Lesson 2: Forcing things to change shape
Starting points	<p>Children make collections of things that move in the classroom. Ask the children to consider:</p> <ul style="list-style-type: none"> • <i>Can you make these things move?</i> • <i>What do they need to make them move? (push/pull)</i> • <i>Why does the toy car stop moving?</i> 	<p>Provide the children with different objects, some that can change shape and some that cannot. Allow the children adequate time to explore how some of the objects can change shape.</p>
Development of lesson	<p>Children can draw the things that move, cut out pictures or make a collage of things that move at home and in the environment.</p> <p>Sort into sets according to what they need to make them move.</p> <ul style="list-style-type: none"> • <i>Which things need a push to move?</i> • <i>Which things need a pull?</i> <p>Ask children to think of other ways of moving the toys. Some children may try blowing the toys or placing them on inclined or flat surfaces. They can then try to make the moving things go faster or slow down.</p> <p>Encourage children to find different ways of stopping an object.</p>	<p>Children should be asked to handle the different objects and change their shape by twisting, squeezing or stretching.</p> <ul style="list-style-type: none"> • <i>Can you make this object change shape?</i> • <i>How can you make it change shape?</i> <p>Sort the objects into two groups. In one circle draw the objects that change shape and in another circle draw the objects that don't change shape. Children should be asked to discuss with each other the pushes and pulls involved in changing the shape of an object:</p> <ul style="list-style-type: none"> • <i>When you squeeze a sponge are you pushing or pulling?</i> • <i>When you stretch the sponge are you pushing or pulling?</i> • <i>When you squash a can are you pulling or pushing?</i> • <i>When you stretch a rubber band are you pulling or pushing?</i>
Extension of lesson: follow-up activities	<p>Children observe objects that move with wheels, such as a pram, tricycle, bicycle, skateboard, wheelbarrow and toy cars. Consider if wheels help objects to move:</p> <ul style="list-style-type: none"> • <i>Can the toys with wheels move quickly?</i> • <i>Can they move a long distance?</i> • <i>Do they need a big push/pull to move?</i> <p>Explore how a large heavy box of toys can be moved. Can we put something underneath it to make it move?</p> <p>Encourage children to try rollers: tinfoil rolls, drinks cans glued together to make a large roll, brush-handles, dowels and cylindrical objects.</p>	<p>Collect materials that go back to the same shape after they have been squeezed or pulled.</p>

Friction

Push a toy car or roll a marble across a table and observe as it slows down and comes to rest. The car stops because there is a force acting on it. Friction is the force that opposes the movement of an object. There are several forces acting on the moving car:

- the forward force from the push that was given to the car. This causes the wheels of the car to turn. The wheels then push on the surface of the table
- the force of friction between the tyres and the surface
- air resistance.

Objects that move through the air experience the frictional force of the air, which acts in the opposite direction to their movement. Air resistance acts against gravity on falling objects. As the speed of the falling object increases, the air resistance increases.

Exemplar 32 illustrates some approaches to exploring friction with children in *third* and *fourth classes*. This activity is also appropriate for *senior classes*.

Gravity

All objects attract one another. The force of attraction which an object exerts is in proportion to its mass. The Earth has a large mass, and so the force of attraction between it and other objects is big, and this force pulls objects to the Earth. This force is called the 'weight' of an object. The weight of an object is a measure of how much the Earth pulls on it.

When you lift a bucket two forces are at work. These are the upward force or pull exerted by you and the downward pull of gravity.

Falling objects

Two objects, such as a pebble and a block, released from the same height above ground will fall at the same rate and reach the ground at the same time. If air resistance is removed all objects fall to Earth at the same rate. Children will find this concept difficult to test, as air resistance cannot be removed. They will discover that a pen and a feather will fall at different rates, as the surface area of the feather is much greater than that of the pen; the feather is therefore affected to a much greater extent by air resistance.

Rolling down a slope

Gravity makes it more difficult to force things to move uphill and easier to force them downhill. Children will find that carrying, sliding and rolling are easier downhill. A slope is a simple machine that diverts part of the force sideways. The extent to which the slope diverts gravity sideways depends on its angle, so that objects take longer to roll down a shallower slope. Children can compare sliding a brick using a rubber band along a level surface, measuring the extent to which the rubber band is stretched. Tilt the surface and force the load to slide uphill. Measurements of the extent to which the rubber band is stretched are taken. Observe and compare the measurements of the force required to slide the load downhill.

Exemplar 33, through focusing on the role of wheels and rollers in movement, provides opportunities for children to investigate slopes and the effects of movement downhill and uphill.

Levers

A lever is a simple machine that turns on a pivot. *Exemplar 34* describes how children might begin to develop a simple understanding of levers in the *senior classes*.

Wheels, axles, belts and chains

Wheel belt systems can be made from thread spools and rubber bands. Children will find that

- an anti-clockwise movement of one wheel creates a clockwise movement of the other
- there is a correlation between the number of turns the small wheel makes and the size of the large wheel.

Exemplar 32

Friction

third and fourth classes

<p>Initial problem: How does friction affect moving things?</p> <p>Background Friction is the force that opposes the movement of an object. Friction is useful in that it prevents too much slipping and sliding. It has drawbacks in that two materials rubbing against each other can cause surfaces to wear away.</p>	<p>Assessment: Techniques that may be used include</p> <ul style="list-style-type: none">• teacher observation: willingness to try different ideas; willingness to work with others• portfolio: annotated drawings of work. <p>Resources Wheeled toys, plastic bottles and cans; different surfaces, such as carpet, smooth tiles, a plank or bread board, to use as a ramp or slope.</p>
--	--

<p>Starting points observation</p> <p>Development of lesson predicting</p> <p>measuring experimenting</p> <p>fair testing</p> <p>Extension of lesson: follow-up activities</p>	<p>Children play with toy cars and lorries and ramps.</p> <ul style="list-style-type: none">• <i>What happens when the car travels down the slope?</i>• <i>What makes the car move?</i>• <i>Can you get the car to go up the slope?</i> <ul style="list-style-type: none">• <i>How far do you think the car will travel when it moves down the slope?</i>• <i>How will you mark where each car stops?</i>• <i>How will you measure the distance?</i> <p>Children move the car down slopes. Place different surfaces, such as carpet, tiles or sandpaper, at the bottom of the slope.</p> <ul style="list-style-type: none">• <i>How far will the car travel on the smooth surface?</i>• <i>Which surface has most grip (that is, creates the most friction)?</i> <p>Encourage the children to consider how they will make a fair test. The factors they should keep the same are the angle of the slope, the cars used, the push given to each car and the way the distance travelled is measured. The variable they will change is the surface on which the car travels. Children will plan a test to establish which type of shoe gives the best grip. Initial discussions on moving in socks, runners, bare feet, leather shoes. The children might observe and compare the soles of the different types of shoes that are to be examined. They might make prints of the different soles. A slope could be used to test the grip. Children can test to establish which objects can be moved easily in water.</p> <p>Note: This theme may be developed as a lesson or as a unit of work.</p>
---	--

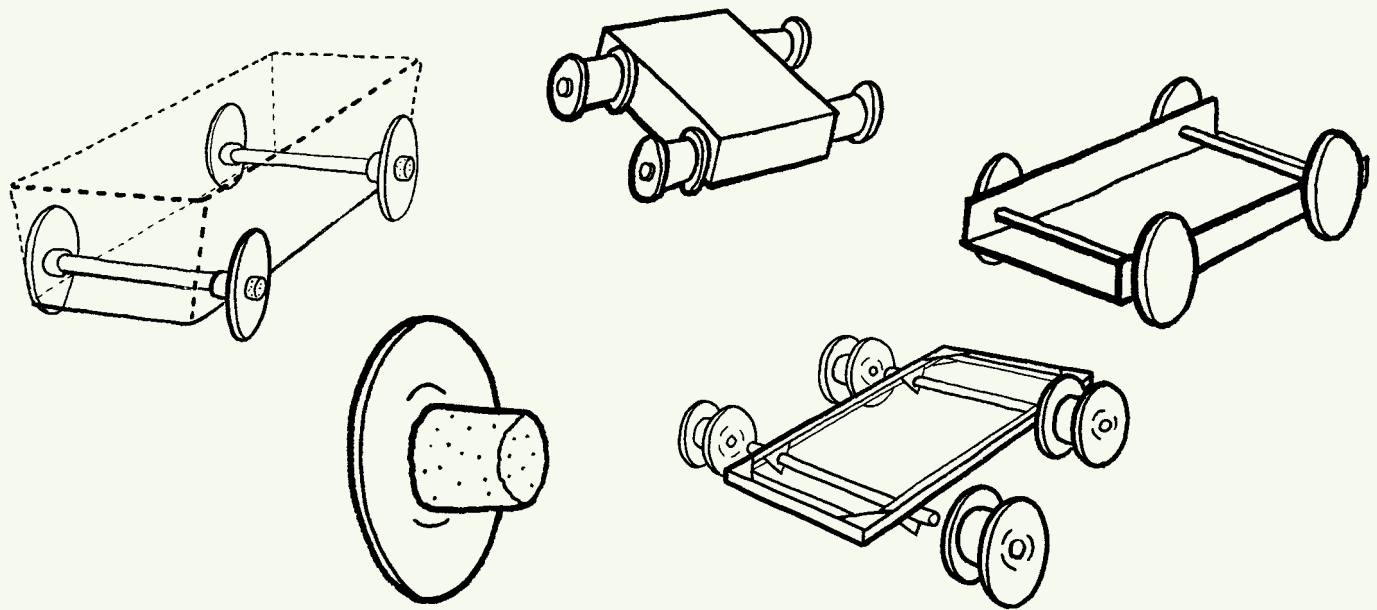

Axes on a basic rectangular chassis, wheels made from thread spools or circles of cardboard

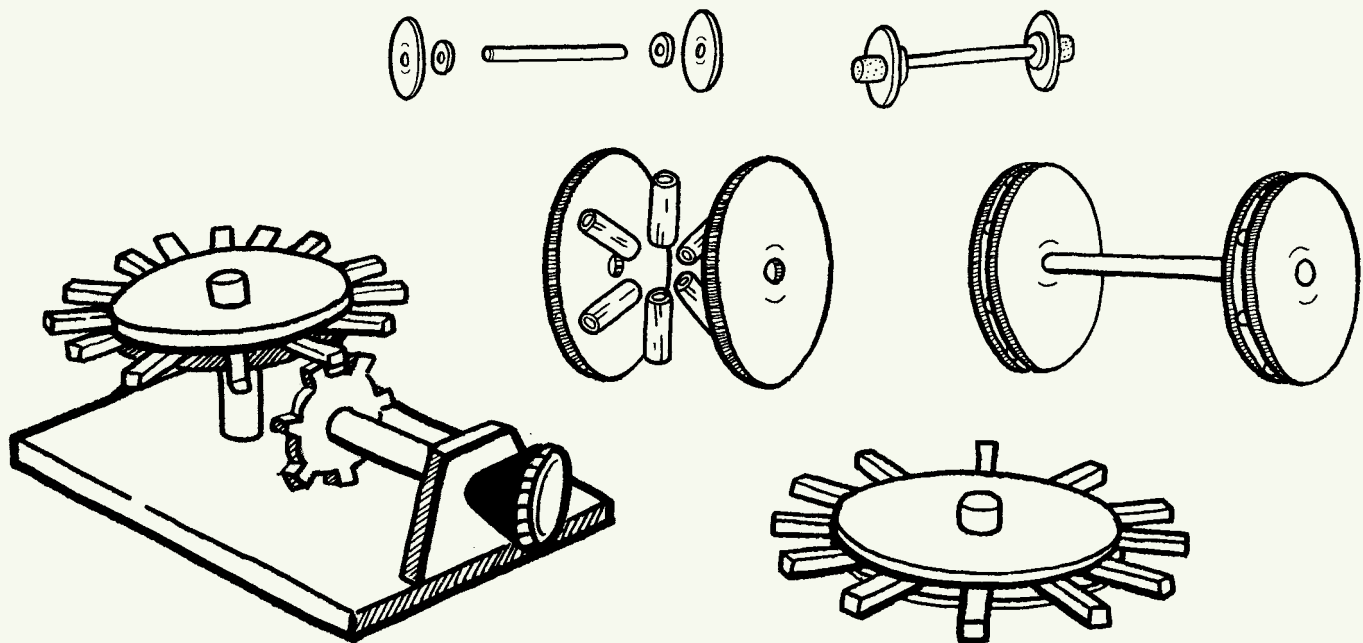

Wheels made from two pieces of cardboard, strawspokes glued between the card circles

Exemplar 33

A unit of work on machines—wheels, gears, chains and belts

third to sixth classes

<p>Initial problem: Can wheels help us to make things move?</p> <p>Background Reducing the amount of surface contact between the vehicle and the surface on which it travels makes movement easier:</p>	<p>Assessment: Among the techniques that may be used are</p> <ul style="list-style-type: none"> • teacher observation: willingness to try different ideas; willingness to work with others • portfolio: annotated drawings of work. 	<p>Resources Dowels, pencils, blocks of wood, rubber bands, straws, glue, cylinders, forcemeter, metre stick, washers, thread spools, marbles, straws, brass pins, empty cereal boxes or strong cardboard for the chassis.</p>
<p>Starting points</p> <p>Development of lesson</p>	<p>Lesson 1: Making movement easier</p> <p>Explore different ways of moving things from place to place, for example sliding (pushing or pulling). Children should try moving small blocks of wood over the same surfaces. Attach a paper clip to each block and secure with tape. Fasten a rubber band to the paper clip. Move the block by pulling the rubber band. Measure with a ruler the length to which the rubber band is stretched. If available, use a forcemeter (instead of the rubber band) to measure the force required to move the block. Children can discover the force needed to move the block when loaded with different objects, such as bricks.</p> <p>Compare the force required for sliding and rolling. Objects that are round, such as a ball, tyre, barrel or drum, can be moved by rolling. Children can select different cylindrical objects filled with sand and with lids securely fixed. Fasten a paper clip to one end of the cylindrical tin with tape and attach a rubber band to the clip. Stand the tin upright and slide the tin along the surface. Measure with a ruler the length to which the rubber band is stretched. Repeat the experiment with the tin on its side. Compare the force used to slide the tin with that used to roll it. Link work with previous experiments involving gravity by asking children to compare the forces required to slide and roll objects uphill and downhill. Children should infer from their experiences that rolling round things is easier than sliding them. Moving objects downhill is easier than moving them uphill, because of the downward pull or force of gravity.</p>	<p>Lesson 2: Investigating rollers and wheels</p> <p>Rollers: moving a load using rollers Ask the children to consider how they will move a brick by rolling rather than by pushing or pulling. Try making rollers from different objects, such as dowels, pencils, thread spools or a lid placed on some marbles. The children should mount the brick on the rollers. Attach a rubber band to the brick and pull, so that it begins to move on the rollers. The children should observe, or measure with a ruler if possible, the extent to which the rubber band is stretched while the brick is moving. Ask the children to consider how they will continue to move the brick, i.e. having to move the rollers from the back to the front. Consider the disadvantages of this system.</p> <p>Exploration Children observe and investigate wheeled toys, such as cars, trucks, dumpers and tricycles. They should note the size and number of wheels in use on the various wheeled vehicles and the ways in which the wheels are fixed on toy motor cars and other toys. The children should also observe how wheels are fixed on any models made from children's construction sets, for example Meccano or Lego Technic.</p>

	<p>Lesson 3: Making wheels, axles and a chassis</p> <p>Ask the children to design and make a car or wheeled machine that can be used to move loads.</p> <p>Making wheels, axles and a chassis</p> <p>Develop craft handling skills of cutting out circles from cardboard, punching holes in milk carton tops, gluing hubs made from bobbins or corks to wheels.</p> <p>Children explore freely how a range of wheels and axles can be made. They may wish to explore how the wheels will be attached to the axle. Brass pins, glue and crosspieces may be suggested.</p> <p>The children may also consider the number of wheels to give to the vehicle. Examples of different wheeled vehicles or machines should be examined, for example scooters, tricycles, prams and lorries.</p> <p>Children should make large and small wheels and investigate the advantages and disadvantages of using pairs of these wheels in their designs.</p> <p>Designing wheeled vehicles</p> <p>Children develop a design plan for the wheeled vehicle, taking into account the materials available. The design may be built initially from construction sets. Children review the design if necessary.</p> <p>Making the wheeled vehicle</p> <p>The children may suggest making the vehicle in different stages, such as</p> <ul style="list-style-type: none"> • wheels • axles • joining wheels and axles • making a chassis • fixing wheels and axle to the chassis. <p>They may identify several problems with their design:</p> <ul style="list-style-type: none"> • cardboard wheels may be weak and need to be strengthened • friction between the axle and the chassis, giving rise to lack of movement • friction between the wheels and the chassis <p>The children may suggest resolving these problems by</p> <ul style="list-style-type: none"> • adding straw spokes to the wheels to strengthen them • making a bracket for the underside of the chassis to which the axle can be placed • adding a spacer between the wheels and the chassis. <p>Evaluating the design: Children evaluate design in terms of movement and ability to carry a load. Consider ways of moving the vehicle: using wind power (attach a balloon), using rubber bands or attaching batteries and a motor.</p>	<p>Lesson 4: Wheel-belt systems</p> <p>Discuss where wheels joined by a belt or a chain may be found; children may suggest a bicycle, vacuum cleaner, fridge or food mixer.</p> <p>The teacher will hammer four nails into a board. For the initial activity place two empty thread spools onto two nails. The spools will act as wheels. Stretch a rubber band around the spools. Mark each spool with a crayon dot.</p> <p>Children should be encouraged to predict what will happen to the second wheel when the first wheel is turned in one direction. The prediction can then be tested. The children should watch the dot on the rim of each spool and record whether the spool moves to the left or to the right.</p> <p>Predict what will happen if the rubber band is crossed over. The children can test this. Record the results.</p> <p>Increase the number of spools used on the board. Connect the spools in different ways with rubber bands. Start each belt system with the left-hand spool.</p> <p>Join two spools, one of which is much larger than the other. Mark a starting point on each spool. Predict what will happen to the large spool if you turn the small wheel once, twice, or three times.</p> <p>The children should consider what will happen to the small wheel when the large wheel is turned. They make predictions and then carry out the test.</p> <p>Work on wheel-belt systems will lead on to a study of wheels with cogs and gears. Examine an egg-beater to observe how the gears are connected. Observe how the big gear makes the smaller gears turn.</p> <p>Children should notice what happens when the handle is turned. Record how many turns the small gear makes for each turn of the large gear. Compare the number of teeth that the small and the large gears have.</p>
<p>Starting points</p> <p>Development of lesson</p> <p>Concluding activity</p>		

Exemplar 34

Levers

fifth and sixth classes

Initial problem: How does a lever work?

Background

The force needed to push the door decreases as the distance from the pivot (the hinge) increases.

Assessment: Among the techniques that may be used are

- teacher observation: willingness to try different ideas; willingness to work with others
- portfolio: annotated drawings of work.

Resources

Ruler, heavy book, something the ruler can turn or pivot on.

Starting points

Open the classroom door. Children could be invited to try closing it using one finger only. Encourage them to predict where it would be best to put their finger (close to the hinges or far away from the hinges).

Development of lesson

measuring

experimenting

inferring

Place a ruler on a pivot so that it functions like a see-saw. Place a book on one end of the ruler and put your finger on the other end about 2 cm from the pivot and press down.

- *Is it easy to lift the book?*
- *Now move your finger 3 or 4 cm from the pivot and press on the ruler. Does it get easier or harder to lift the book?*

Children should conclude that the lever works well when the pushing force is far away from the turning point or pivot.

Extension of lesson:

follow-up activities

Children should experiment on a see-saw to find out what difference weight (mass) and distance from the pivot make to balancing the see-saw. There are opportunities here to predict and measure.

Note: This theme may be developed as a lesson or as a unit of work.

Approaches to learning about humans

Variety among humans and human characteristics

Organisms in a group have many characteristics in common. This is what helps us to recognise a cat as a cat or a tree as a tree. People are similar to each other in many ways: for example, they have skin, eyes and hair. They have organs inside their bodies, such as heart, lungs and stomach.

Individuals in any group of organisms will differ in some characteristics; this is an example of variation. People are different in many ways, and it is often these differences that children first notice. Differences help us to identify individuals. Differences that are easily recognised include eye and hair colour, height and shoe size.

We inherit certain characteristics from our parents, for example height and eye colour. Some characteristics, such as height or quality of teeth, can be influenced by factors such as diet. A healthy, nutritious diet may make children grow taller than their parents. Strong teeth may be inherited from parents, but a diet that is full of sugars may cause tooth decay.

In the early years children will be introduced to the external parts of the body. Later on they will learn about the major organs and organ systems, both external and internal. It is important that children realise that there is great variation among all organisms. Not only will this make them aware of their own uniqueness but it may also encourage more tolerance of other people. It may also help them to cope with the rapid changes and growth that will take place as they come towards the end of primary school.

Exemplar 35

Human variety and characteristics

infant classes

Initial problem: To identify the parts of the body and to become aware of similarities and differences.

Background

The concept of variation is an important one. Children tend to notice differences more easily than similarities, and sometimes emphasis needs to be put on the latter.

Assessment: Among the techniques that may be used are

- teacher observation: willingness to try different ideas; willingness to work with others
- portfolio: annotated drawings of work
- concept maps.

Resources

Partial pictures of bodies and cut-outs of missing parts.

Starting points

Development of lesson

observation

recording

Extension of lesson:

follow-up activities

observation

comparing and analysing

sorting and grouping

Parts of the body

Show the children an outline of a head and a torso.

Let the children examine cut-out arms, legs, eyes, and so on. They identify them and stick them on the picture in the appropriate place.

Less noticeable features, such as eyebrows, eyelashes, thumbs and number of digits, could be dealt with later.

Children could discuss what their own faces look like, for example eye colour and hair colour.

They could then be asked to make the face like their own.

Differences and similarities

Children are asked to draw a picture of themselves or talk about what they look like.

Ask them to consider:

- *How are you the same as or different from your friend?*
- *Have you both got hair, eyes and so on?*
- *How is your hair or face different?*
- *How do your friends know who you are when they look at you?*

Play a guessing game where the teacher thinks of a child and gives clues. The children try to name the child from the clues: for example, *My hair is black, my eyes are brown, and I have a ponytail. Who am I?*

Make a set of children with blue or brown eyes.

Make a set of children with fair or brown hair.

Note: This theme may be developed as a lesson or as a unit of work.

Exemplar 36

The body's internal organs

middle classes

Initial problem: When I breathe in, where does the air go?

Background

Children will have heard about such things as the heart, lungs and stomach. They probably will not have given much thought to the size and position of each organ.

Assessment: Among the techniques that may be used are

- teacher observation: willingness to try different ideas; willingness to work with others
- portfolio: annotated drawings of work
- concept maps.

Resources

Large sheets of paper.

Starting points

Ask children questions such as

- *Where do you think your lungs are?*
- *How big are they?*

Development of lesson observation

Children could draw an outline of their bodies on a big sheet of paper and then draw in where they think their lungs are and what size they are.

Their ideas could then be checked against drawings in textbooks or models.

testing

The children's ideas of how air gets from their nose to the lungs could be investigated and suggestions added to the drawings.

Children could be invited to feel their throat with their fingers and describe what their windpipe feels like. The term bronchus could be introduced, as many children will have heard of bronchitis.

comparing

Attention could be paid to the different shape and size of noses in the class, thus emphasising the idea of variation.

Extension of lesson: follow-up activities

Other internal organs, such as those of the blood and digestive system, could be dealt with in similar fashion. Papier mâché models of these organs could be made.

designing and making

Models to indicate the length of the intestine (about 8.5 m) and the size of the heart could be provided.

Note: This theme may be developed as a lesson or as a unit of work.

Human life processes

The following life processes can be observed in humans: growth, feeding and digestion, respiration and breathing, movement, sensitivity, excretion and reproduction. Children will be introduced to simple aspects of these processes. They will also learn about factors that contribute to good health, including diet, life-style, personal hygiene, dental care, rest and exercise.

Growth is a gradual process, in which there is an increase in the size of the organism. Children could produce evidence of their growth and development through making collections of photographs, clothes and shoes. Children should appreciate that they grow at very different rates.

Digestion is the process of breaking down food into particles small enough to be absorbed by the gut wall. The blood carries the broken-down food to the cells of the body, thus acting as a transport system. Models of the inside of the body and cut-out pictures can help them clarify their ideas about digestion and the circulatory system. Heartbeat and pulse rates can be compared before and after exercise.

A similar approach can be used to develop ideas about respiration and breathing. Respiration is the process by which food combines with oxygen to produce energy. Oxygen is provided when we draw air into our lungs by breathing in, and waste, in the form of carbon dioxide, is removed when we

breathe out. Children can discuss their ideas of breathing and the position and size of the lungs and other parts of the respiratory system. In the *senior classes* children can suggest ways to measure the amount of air they breathe in and to record and predict breathing rates before and after exercise.

Humans are supported by an internal skeleton of more than 200 bones. Movement of these bones and joints is brought about by muscles. Activities in physical education lessons such as running and jumping may make children aware of movements of bones and muscles. Movements of different bones and joints could be examined in detail and children could make models of limbs from cardboard and rubber bands.

Humans have sense organs such as skin, ears, eyes, nose and tongue with which they can respond to changes in the environment. Children can discover how one sense depends on another by devising games in which they are prevented from using one of their senses, for example trying to identify objects by touch alone without being able to see the object.

In the *senior classes* children will become familiar with life cycles and this concept can be linked with human reproduction. Questions about where living things come from and where babies grow before they are born may help children to clarify their ideas. Children may not be familiar with terms such as sperm, womb and so on, and it would be important to establish a suitable vocabulary.

Exemplar 37

Human life processes

infant and junior classes

Initial problem: What do people need to live and grow?

Background

Children can sometimes be unsure of what is living and non-living. Exercises to help them sort out their ideas in this area can be useful before considering what needs living things have.

Assessment: Among the techniques that may be used are

- teacher observation: willingness to try different ideas; willingness to work with others
- portfolio: annotated drawings of work
- concept maps.

Resources

Cards with pictures, seeds such as cress.

Starting points

observation

recording

Living and non-living

Children's ideas of what is living and non-living can be explored in different ways; for example, they could be asked to look around the room and talk about what is living and non-living.

They could explore the school grounds and draw everything they think is living.

Ask children why they think various things are living. Children often give movement as a reason for being alive and therefore rarely include plants in their lists of living things.

Discussion of what happens to living and non-living things may help children sort out their ideas.

- *When you cut your hair does it grow again?*
- *When you break the crayon does it grow again?*
- *What makes the television work?*
- *Do you have to be plugged in or switched on?*
- *Does the teddy eat food?*

Development of lesson

observation

communicating

Needs of living things

Children discuss how they have changed since they were babies.

Photographs could provide the basis for discussion:

What sort of needs have they (food, sleep, drinks, clothes, shelter)?

Children can draw pictures of their favourite foods. They can describe how they feel if they have not eaten for a long time.

Children can consider:

- *Do children sleep as much as babies?*
- *Why do people need to sleep?*
- *Why do children and adults need to eat?*

Extension of lesson:

follow-up activities

sorting and grouping

Provide children with pictures and ask them to sort them into living and non-living. Ask children to give reasons why they think a particular thing is alive or not alive. Seeds could be germinated and grown as a link with plant processes.

Sort foods into sets according to likes and dislikes.

Use photographs to compare the foods, clothes and types of shelter that people in different climates need.

Note: This theme may be developed as a lesson or as a unit of work.

Exemplar 38

Human life processes

middle and senior classes

Initial problem: Why do people need food?

Background

Foods are divided into the meat group, fruit and vegetable group, cereal and potato* group, and milk group. A balanced diet will include food from each group. Children sometimes talk about bad foods. They should become aware that there are unbalanced rather than bad diets.

*Even though potato is a vegetable it is grouped with cereals, because it has a lot of starch.

Assessment: Among the techniques that may be used are

- teacher observation: willingness to try different ideas; willingness to work with others
- portfolio: annotated drawings of work
- concept maps.

Resources

Tinned food, packet food; information on food groups and pyramids.

Starting points

recording

sorting

comparing

Ask the children to make a list of the foods they have eaten the previous day or to describe their favourite meals.

Explain that one way of sorting food is into the four food groups:

- meat
- fruit and vegetables
- cereal and potato
- milk.

Ask them to examine the meals they have listed and to see if they have food from each group in their list; that is, whether they have a balanced and healthy diet.

Development of lesson

sorting and grouping

Pictures or lists of meals, some of which are balanced, for example fish, peas and potatoes, and some of which are unbalanced, for example sausages and chips, can be examined.

The children could sort them into healthy and unhealthy.

They could then plan some healthy menus and lunch-boxes.

Extension of lesson

The idea of a healthy diet pyramid could be introduced. Foods provide different things, for example,

- sugar, starch, bread and potato provide energy
- fats provide energy
- fish or lean meat is needed for growth and repair
- fresh fruit and vegetables provide vitamins
- fibre comes from fruit, vegetables and wholemeal bread.

Research the information about food that is given on labels on cans and on packets.

Research diets of people from different cultures.

Note: This theme may be developed as a lesson or as a unit of work.

Approaches to learning about materials

'Materials' is the name given to the group of substances that objects are made from, including

- metals
- plastics
- fibres
- textiles
- ceramics
- rubber
- wood
- glass
- rocks
- water
- air.

Materials can be classified in many different ways. They can be divided into natural materials, which come from animals and plants and the Earth's crust, and manufactured or synthetic materials, such as glass, paper and plastics, which are made from other materials. Materials may be solids, liquids or gases, for example wood, water or air.

Materials can be classified according to type, for example metals, ceramics, plastics or fibres. Fibres can be subdivided into two sub-groups:

- natural fibres, for example cotton, wool and silk
and
- synthetic fibres, for example nylon and acrylic.

Materials can be grouped according to their properties, for example strength, transparency, flexibility, hardness, conductivity of heat or electricity or magnetism. They can also be grouped according to their uses, for example in building, as clothes or as food.

Materials can be examined in detail and grouped into sets according to weight, strength and flexibility. The children should explore how materials can be changed through the investigation of the effects of heating and cooling on a range of materials and the changes that are brought about when materials are mixed. They will also be introduced to ideas about filtering, evaporation, dissolving and suspension.

Materials and change

Materials can be changed in different ways.

Materials can undergo physical changes, where the form and shape of the material is changed. Physical changes usually do not result in the production of a new substance. Examples of physical changes include the freezing of water, bending, cutting materials and making shapes out of Plasticine.

Materials can be changed by mixing. This sometimes improves their properties: for example, steel is a mixture of iron and carbon. Sea-water and soup are both mixtures. Sometimes we need to separate these mixtures, and various techniques, such as filtering, decanting and evaporation, can be used.

Materials can be chemically changed to produce another material. For example, chemical changes occur when you burn paper. Rusting is another example of a chemical change, as is cooking an egg.

Exemplar 39

Properties and characteristics of materials

infant classes

<p>Initial problem: What are things made of?</p> <p>Background Young children often group things according to colour or how they feel, less often according to what they are made of.</p>	<p>Assessment: Among the techniques that may be used are</p> <ul style="list-style-type: none">• teacher observation: willingness to try different ideas; willingness to work with others• portfolio: annotated drawings of work• concept maps. <p>Resources A variety of common objects found at home or in school.</p>
---	--

<p>Starting points</p>	<p>Children's interest can be captivated by a story like 'Cinderella', where objects are made of inappropriate materials or a parcel could arrive with a toy inside it.</p> <p>Discussion about all the different materials could ensue.</p>
<p>Development of lesson</p>	<p>Observation of a variety of objects will be stimulated by questioning; for example,</p> <ul style="list-style-type: none">• <i>What do you think this is made of?</i>• <i>Could you find out more?</i> <p>Encourage the children to find out more about the materials through</p> <ul style="list-style-type: none">• <i>touching materials</i>• <i>scraping materials</i>• <i>examining materials with a hand lens.</i>
<p>observing</p>	
<p>recording</p>	<p>Children can describe their findings orally or in drawings.</p>
<p>sorting and grouping</p>	<p>A collection of objects could be sorted into two groups. Children could suggest groups, or they could be directed to sort into groups such as hard/soft, heavy/light, smooth/rough.</p>
<p>Extension activities</p>	<p>Closer attention could be focused on groups, for example fabrics or metals. Children could consider what materials are used for. The idea of solids and liquids could be introduced, and children could discuss their ideas of the nature of solids and liquids.</p>

Exemplar 40

Mixing and other changes

first and second classes

Initial problem: What happens to things in water?

Background

Children often confuse melting with dissolving. They need to realise that melting occurs when heat is applied, whereas dissolving does not require heat. Children should explore a range of materials.

Safety

Washed sand should be used in science investigations.

Assessment: Among the techniques that may be used are

- teacher observation: willingness to try different ideas; willingness to work with others
- portfolio: annotated drawings of work
- concept maps.

Resources

Salt, sugar, sand, instant coffee, flour, water, jars and spoons.

Starting points

observing
communicating

Drinking tea could be a topic of discussion.

- *Do you know people who put sugar in their tea?*
- *What will happen to the sugar?*
- *Will the tea taste the same?*

Development of lesson

predicting

Children will be asked to predict:

- *What do you think will happen if you add some salt to a jar of water?*
- *What do you think will happen if you add some sand to water?*
- *How could you find out?*

experimenting
fair testing

Children will be encouraged to devise a fair test: for example, they will add the same amount (a teaspoon) of sand and salt to the water, they will use the same amount of water, the water will be of the same temperature and they will stir the same number of times. The only variable being changed is the substance being added to the water. The children will observe that the substance has dissolved when the liquid is clear and transparent..

observing

Observation will be encouraged by questioning:

- *What changes are there in the water?*
- *After you stir, is the water clear and transparent?*
- *After stirring, are some grains of sand or salt floating in the water?*
- *What has happened to the salt?*
- *What has happened to the sand?*

Extension activities

Children can investigate what happens when different substances are mixed in water. Consider:

- *Would warm or cold water be better?*
- *Which things dissolve first?*
- *Do some things take a long time to dissolve?*
- *Can some substances dissolve without stirring?*
- *Which things dissolve when they are stirred?*
- *What happens to the things that don't dissolve?*

Exemplar 41

Properties and characteristics of materials

first and second classes

<p>Initial problem: What will I use to mop up the water?</p> <p>Background Children do not usually classify materials according to what they are made of, for example plastic, wood, etc. They could be introduced to the idea that there is a link between the properties of a material and the uses to which it is put.</p>	<p>Assessment: Among the techniques that may be used are</p> <ul style="list-style-type: none">• teacher observation: willingness to try different ideas; willingness to work with others• portfolio: annotated drawings of work• concept maps. <p>Resources Paper, soft plastic, Plasticine, cloth.</p>
---	--

<p>Starting points</p> <p>observing</p>	<p>A wet day could be a topic of discussion. The children could observe and discuss the type of clothing worn, for example a raincoat or a hat.</p> <p>Children's ideas about the absorbency of different materials can be clarified through questions such as:</p> <ul style="list-style-type: none">• <i>What does it look like?</i>• <i>What does the material feel like?</i>• <i>Does it soak up water?</i>• <i>Does it keep water away from you?</i>
<p>Development of lesson</p> <p>predicting</p>	<p>Make a collection of materials, for example cloth, different types of paper, plastic and wool. The children should consider:</p> <ul style="list-style-type: none">• <i>Which of these would be best for mopping up water?</i>• <i>How would you find out?</i>
<p>experimenting</p> <p>fair testing</p>	<p>The children could put a little water on a tray and use different materials to soak up the water. They should be encouraged to make the test fair, for example to use</p> <ul style="list-style-type: none">• <i>the same number of wipes</i>• <i>the same amount of water</i>• <i>the same container</i>• <i>an equal-sized sample of each material to be tested.</i>
<p>recording</p>	<p>The results of the test should be recorded.</p>
<p>Extension activities</p>	<p>Links between the suitability of materials and their uses could be explored in the context of houses: for example, why do we use glass for windows, bricks or cement for walls?</p> <p>Tell the story of 'The Three Little Pigs'. Discuss the materials that were used for each house. Consider the effectiveness of each material.</p>

Exemplar 42

Solids, liquids and gases

third and fourth classes

Initial problem: What are solids, liquids and gases?

Background

Many children will not use these terms, and in particular they will have difficulty with the idea of gases. The purpose of these activities is to help them to identify the properties of solids, liquids and gases.

Assessment: Among the techniques that may be used are

- teacher observation: willingness to try different ideas; willingness to work with others
- portfolio: annotated drawings of work
- concept maps.

Resources

A range of materials, which include examples of solids, liquids and gases, (for example balloons and tyres, which contain gases when inflated), fizzy drinks, bubbles, the air in the classroom.

Starting points

Development of lesson

sorting and grouping
comparing

inferring

Solids, liquids and gases

Most children have drinks in their lunch boxes. Introduce them to the term 'liquid'. Ask them to think of other liquids and to make a list of liquids that they can find at home and in school.

Observation can be encouraged by asking the children to describe different liquids. They should consider:

- *How are they the same/different?*
- *How do we know that orange juice is a liquid?*
- *Do all liquids pour?*

Solids

Children can make a collection of different solids. Encourage them to include:

- solids that are made from soft materials, such as cotton wool or a sponge
- solids that are transparent, such as glass and plastics.

The children's ideas about solids can be refined through questioning:

- *Are all these solids the same?*
- *Can a soft material like cotton wool be a solid?*
- *How can solids be identified?*

The children might compare solids with liquids. Some solids change shape and pour like liquids. As a result, some children find it difficult to distinguish between some soft solids (flour, powder, icing sugar) and liquids.

The children can consider:

- *What happens to materials when they are turned upside down?*
- *Do any materials change shape or spread about?*

Some liquids, such as oil, treacle and honey, can also pose problems for children. They may describe these liquids as solids, because they do not pour as easily as other liquids, such as water.

Gas

When asked about gas, children often think of gas used for cooking and fires. The following experiences can help them to think about other gases.

- *Blow up a bag or a balloon. Push the balloon. What can you feel?*
- *Observe a mobile suspended over a radiator*
- *Record wind direction and speed.*
- *Open a bottle of perfume. What happens?*

Exemplar 43

Materials and change

fifth and sixth classes

Initial problem: Why do we use a wooden spoon to stir something hot?

Background

Heating is a means by which energy can be transferred. Some materials, such as metals, are good conductors of heat. Materials that are poor conductors of heat are described as insulators.

Assessment: Among the techniques that may be used are

- teacher observation: willingness to try different ideas; willingness to work with others
- portfolio: annotated drawings of work
- concept maps.

Resources

A collection of spoons (wooden, plastic and metal), butter, a source of heat (controlled by the teacher).

Starting points

A collection of spoons could be sorted into wood, plastic and metal. Children should consider the question:

Which spoon is best for stirring something hot? Why?

Development of lesson

Children may suggest that the plastic spoon would melt or that the metal spoon would get too hot. These ideas can be clarified through questioning:

- *What do you think will happen if I put a wooden spoon and a metal spoon into the same hot water?*
- *Which will get hot faster?*
- *If I put a lump of butter on the spoon handles, what will happen?*

The idea of a fair test should be emphasised: for example,

- *Are the lumps of butter in the same position on the spoon handles?*
- *Are the spoons the same size?*

Questioning the children as they experiment will focus their observations and encourage them to analyse the results:

- *Which lump of butter is melting?*
- *What do you think is happening?*

The term 'conductor' could be introduced, and the idea that a metal is a good conductor could be discussed.

Children can consider:

- *Do you think wood is a good conductor?*
- *Do you think it would be a good insulator?*

predicting

hypothesising

investigating and
experimenting

analysing

Extension activities

investigating and
experimenting

Children can be prompted to design a test to see which materials are good insulators. They choose materials (cotton, nylon, woollen jumper, velvet). Encourage them to think of ways of testing their idea. Some children might decide to fill some cans with warm water and to wrap the material around each can.

Children should be encouraged to make their test fair:

- use the same amount of water in each can
- use the same type of can
- take the temperature of the water at the same time
- use the same amount of material to wrap the can.

Check the temperature of the water in the cans after 5 minutes and after 10 minutes. Children should record and analyse their results.

Children might use secondary sources to find out about clothing in different hot and cold countries.

recording

Approaches to learning about heat

Link work on the strand unit 'Heat' with the strand unit 'Materials and change'. Exemplar 43 outlines some activities that will link with this topic.

Work on this strand unit integrates with strand units from the geography curriculum. These strand units are

- Air
- Water
- Weather, climate and atmosphere
- Planet Earth in space.

Heat transfer is the way in which heat is moved: in solids by conduction; in liquids and gases by convection; and from a hot object, like the sun or a stove, by radiation. The children can use their sense of touch to compare water at different temperatures, for example from cold to luke-warm. They should appreciate the need for a more standard measurement of hotness and should be encouraged to use thermometers to check the temperature of things. They should recognise that temperature is a measure of how hot something is.

The children's ideas about heat will be developed as they work with different materials. The strand unit 'Materials and change' will provide them with opportunities to explore the effects of heating and cooling as they investigate the properties of different materials. In the *middle* and *senior classes* they will learn about the different states of matter and will explore the effects of heating and cooling on solids, liquids and gases.

Exemplar 43 illustrates how children can explore the effects of heat on different solids. It also outlines how children can be introduced to the idea of materials that insulate or conduct heat.

In the *senior classes* children will be introduced to the use of fossil fuels as non-renewable sources of heat and to renewable forms of energy, such as wind, water and solar energy. Children can design and make windmills, which make use of the energy of the wind, or water wheels, which make use of the energy from water, to help them develop ideas about renewable sources of energy. They should become aware of the importance of conserving energy and be encouraged to use simple measures such as closing doors and turning off lights.

Safety

The teacher should be very careful in the organisation of tests involving the use of hot water: the children should use water that is safe for them.

Environmental awareness and care

The Teacher Guidelines for SESE: History provide guidance for teachers on

- using photographs
- using evidence
- interviews.

The Teacher Guidelines for SESE: Geography illustrate the following methods and approaches, which will support the teaching of environmental issues:

- field trips
- learning about the natural environment
- the local environment.

The Teacher Guidelines for Social, Personal and Health Education provide guidance on

- working in groups
- dealing with controversial issues
- using photographs.

Children's experience of science should lead to an informed appreciation of the environments that they encounter. Pupils should develop an awareness of the interdependencies of natural environments, plants and animals (including humans) in local, national and global contexts. Much of this work will be achieved by the children as they explore the strands and strand units of the geography and science curricula.

Both programmes emphasise the need for the pupils to develop an understanding of the impact of human activity on the environment. It is important that the exploration of natural and physical environments should foster positive environmental action and encourage children to develop a commitment to sustainable life-styles. Through the exploration of environmental issues children should be imbued with a sense of personal and community responsibility as custodians of the Earth.

Helping children to develop their ideas about environmental issues and cultivating attitudes of environmental care can be achieved using a variety of methods and approaches. Some of these methods are delineated in the guidance material provided for history, geography and SPHE. However, specific methods that may be used in science include:

Visits and field trips to areas undergoing change

Children can be encouraged to appreciate how humans can affect their environment through visits and field trips to areas that are changing. These could include:

- a field that is becoming a building site
- a river that is being drained or whose course is being altered
- a derelict area being converted into an industrial centre
- mountain land being planted with conifers
- a telecommunications aerial being erected on a hillside or roadside
- fields whose size is being increased through the removal of hedgerows.

The sites visited should help children develop a balanced understanding that human influences on local and natural environments are widespread, in rural as well as urban areas. Children can make annotated drawings of the areas visited. Follow-up visits can help them record the changes and developments observed in the area over an extended period.

Interviews

Children can invite an older person who has lived in the locality to come and talk to them about changes that have occurred. Guidance on approaches to interviews is given in the *Teacher Guidelines for SESE: History* (p. 78–80). Books, photographs and old newspapers can supplement this work.

Participation in local environmental projects

Projects to improve the environment may already be under way in the locality. These projects may include the restoration of a historic site, the clearing of a canal, the construction of a park or the renovation of houses in the area. Children should become aware of these initiatives, and visits to the site to view the work in progress should be arranged. It may also be possible for the children to become involved in the project. The principal, parents and board of management should be informed and their permission sought for the involvement of pupils in such a project. It may also be possible for people involved in the environmental project to visit the school and talk to the children about their work.

Participation in environmental projects based in the school environment

Children will be interested in many environmental issues, such as waste and recycling, energy conservation and pollution. These issues may stimulate them to become involved in some school-based projects, which might include

- recycling paper, cans, glass or other materials
- anti-litter and anti-waste campaigns
- conserving resources such as water, heat and other forms of energy
- composting waste.

Involvement in environmental projects should help children to appreciate the need to protect environments and conserve non-renewable resources.

Children should be encouraged to participate in projects to enhance the school and its environs. These might include

- planning and creating a school garden
- creating a wildlife area
- planting trees.

Assuming responsibility for the care of these habitats will help children to explore the concept of custodianship.

Exploring environmental issues

Helping children to become aware of local or national environmental issues will involve them in

- visiting (where possible) the area affected by the issue
- using secondary sources, such as posters, photographs, newspapers, videos and environmental cartoons, to become aware of the issue
- obtaining evidence about the issue or problem through interviews
- simulating (where possible) tests to observe the effects of the problem, for example observing the effects of water pollution on plants, testing the effects of deforestation on soil, smearing leaves with Vaseline to observe the effects of air pollution
- interviewing people involved in the issue to assess their differing viewpoints.

Approaches to designing and making

The technology component of the SESE curriculum, as outlined in the science skills section, is entitled *Designing and making*. Designing and making will involve children in making small-scale objects such as toys or larger things such as lighthouses or trucks. Children should be provided with opportunities to design and make objects that function or work, such as a teddy bear's lunchbox, a pop-up-card, a battery-driven vehicle or a boat powered by a rubber band. The children can then be challenged to think about why their products work and how they can be improved.

Designing and making activities need not always be about practical problem-solving. Children should begin to perceive ordinary objects as examples of technology. Tea-pots, pencil sharpeners, sweeping brushes and chairs are examples of objects that are made to fulfil a need. Common objects can be explored for their design and for their artistic and technological features. Teachers can use their knowledge and skills to help children do this by asking questions such as:

Why is this object used?

Why has it been made in this way?

Are these objects always made from the same materials?

Can other materials be used to make these objects?

Have these objects always been made in this way?

If not, why not? If yes, why?

Opportunities should be provided for children to focus on how familiar, everyday objects are made. Sometimes the children might take things apart, such as a bicycle pump or a torch. They should reflect on how well things work and judge them according to their ease of use, reliability, safety, appearance and texture. Children should reflect on the need to improve, change or develop things already in existence.

Technology and society

It is important that children come to appreciate that technology is part of their everyday experience. Pupils should become aware of the applications of science and technology in familiar contexts; at home, at school, in the community and in the work-place. They should also recognise the contribution that science and technology make to improving the quality of life. The designing and making section of the curriculum aims to provide children with an understanding of the technological process as well as the development of the skills and attitudes required to undertake practical tasks.

Craft-handling skills

An important aspect of designing and making will be to provide the children with craft-handling skills—the skills of making, such as cutting and joining. The tools that children use to design and make may include rulers, staplers, scissors or needles. Some activities in fifth and sixth classes may require the use of tools such as hammers, screwdrivers and saws. Opportunities to practise and acquire accuracy in skills

such as measuring, marking, cutting or shaping will help the children to produce their models and artefacts.

Materials

In designing and making activities children will use a range of materials. These will include construction sets, paper, cardboard, straws, clay, cans, fabric, plastic and wood. Children should examine the properties and characteristics of different materials through observing, comparing and sorting. They can then select the most appropriate materials and tools for the task.

Safety

A safe working environment and safe ways of working should be encouraged at all levels. During designing and making activities children will work with a wide variety of materials and tools. Tools such as craft knives, glue guns or hacksaws must only be used by children who are under the direct supervision of the teacher or a specially designated adult. The teacher should demonstrate the safe use of tools before allowing their use in designing and making tasks. Tools need to be stored in a secure area and children should only have access to tools when supervised. The cultivation of a safe working environment should be considered by the teacher and the school when planning and organising learning in science and technology.

Integration

Designing and making will help children to gain a greater understanding of topics in the geography curriculum such as industries, manufacturing processes and people at work. Opportunities to visit sites such as factories, quarries or workshops to examine the things made in these areas will provide children with direct experience of the design and manufacturing processes. It will also help them to understand that in the world of work certain materials are changed into products by physical or chemical processes.

Exemplars

The exemplars that follow show how a number of designing and making lessons can be presented. The exemplars are based on the strands of the curriculum and may be adapted for use at different class levels.

An important aspect of designing and making tasks is that children are provided with open-ended activities. Pupils should be encouraged to design and make their own models and artefacts. Open-ended tasks will generate a wide range of outcomes. However, in infant and junior classes children may be presented with more focused activities. These will tend to produce a range of similar outcomes. Open and closed technology tasks should provide the children with the scope to generate their own designs and the freedom to devise their own solutions to problems.

Exemplar 44

Designing and making a crayon holder

Initial problem: Can we make a crayon holder for our tables?

Background

Some materials, such as Plasticine and modelling clay, can be moulded into different shapes. Children will have worked with materials such as modelling clay and playdough during informal play. They may suggest using clay or Plasticine to make a crayon holder.

Other children will select cardboard tubes for their design. These children will need to consider how to make bases for their containers and how to stick these bases onto the containers.

Other children may choose materials such as items of reclaimable domestic waste (crisps tins, plastic bottles, squeeze bottles, yoghurt cartons) and modify these artefacts for their own purposes.

The crayon holder should be strong and easy to make. The children should also focus on making the crayon holder attractive as well as functional.

Assessment: Suitable techniques include

- teacher observation: willingness to try different ideas; willingness to work with others
- portfolio : annotated drawings of work.

Resources

Playdough, Plasticine, paper, cardboard tubes, plastic tubs, cardboard boxes, glue, crayons, modelling clay.

Craft-handling skills

This task provides opportunities for the development of the skills of

- cutting
- joining
- modelling.

Safety

Solvent-free glues should be used in designing and making activities.

Exploration

Children can explore the containers that are already in use in the classroom to hold crayons, such as margarine tubs, plastic tubs, tins and cardboard boxes. The children should observe these containers and consider:

- *why they need crayon holders*
- *the shapes of these containers*
- *the crayon holder that is best with regard to*
 - *durability*
 - *ease of opening and closing*
 - *attractiveness—colour and shape*
 - *stability.*

Planning

Consider the materials that can be used to make the crayon container. These might include:

- *paper*
- *cardboard tubes and coffee-jar lids*
- *shoe-boxes with openings*
- *Plasticine or modelling clay.*

The children should consider the most suitable type of container to hold their crayons. They should consider:

- *What shape will the container be?*
- *Will the container be large or small?*
- *Will the container be strong enough to hold lots of crayons?*
- *How can it be made to look more attractive?*
- *How can the container be made suitable for short crayons?*

Making

The children draw pictures of the crayon container.

They decide on the materials to use. The teacher will work with children in small groups who need help in

- *moulding Plasticine or modelling clay*
- *gluing bases to cardboard tubes*
- *cutting cardboard.*

Evaluating

The children should be encouraged to use the crayon holders in the classroom over an extended period. The effectiveness of the design, the suitability of the materials and the durability of the construction will become apparent with use.

Exemplar 45

Designing and making a land yacht

Initial problem: Can we design and make a vehicle that is powered by the wind? (a land yacht)

Craft-handling skills

This task provides opportunities for the development of the skills of cutting, joining, making triangular joins, making holes and strengthening structures.

Assessment: Suitable techniques include

- teacher observation: willingness to try different ideas; willingness to work with others
- portfolio: annotated drawings of work.

A range of solutions may be possible. It is not expected that each child should produce the same outcome.

Resources

A small cardboard box, pieces of plywood of different shapes and thickness, art straws, glue, paint, short canes or dowels, light fabric, wheels from a Lego toy or thread spools.

Lesson 1: Exploring, planning and making

The children make a collection of toy boats. They explore:

- the shape of the base
- the materials used for the base
- the materials used for the sails.

The children should name the parts of each toy. They should then be challenged to consider how the sailing boat could be adapted for use on land. Some suggestions may include

- adding an axle and wheels
- adding a motor.

The children choose suitable materials from a limited range. Sketch designs of the land yacht. Encourage different groups to make their own designs.

The base: chassis, wheels and axle

Some groups may decide to use a cardboard box for the base. Others may choose rectangular pieces of wood, while other groups may decide to assemble rectangular bases from art straws glued to triangular card corners.

The teacher should help children to think about adding wheels to the base. Some children, through their unstructured play with toys, may perceive the need for an axle upon which to place the wheels. Other children will need to be directed to add an axle to their design. Dowels or pieces of cane/bamboo may be appropriate materials for axles.

The children should be challenged to consider how to join the axle to the base (chassis). Triangular pieces of strong card can be cut out by the children. The children can then use a paper punch to punch holes in the triangle. The triangles should then be glued to the base. Leave to dry before pushing the axle through.

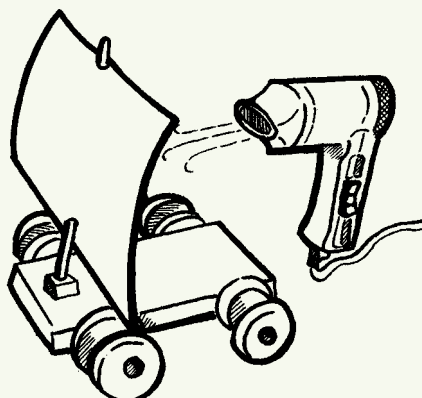

Lesson 2: Making and evaluating

Children use thread spools or cut circular pieces of card for wheels. If cardboard wheels are made then consideration should be given to the size of the wheels used and how to strengthen them. Some children may suggest using two circular pieces of cardboard.

Punch a hole in the wheel with the paper punch. Push the wheel onto the axle. Children should consider how to prevent the wheel falling off the axle. Consider using washers, plastic tubing or pieces of cork for the hubs.

The mast

Consider the materials that will be used for the mast. Pieces of dowel or bamboo cane may be used. The children should decide where to attach the mast to the boat. The mast should be attached to the base. The children may consider doing this by

- gluing
- drilling a hole in the base and gluing the mast into the hole (teacher-assisted)
- using tape.

Decide on the materials that will be used for the sail. If fabric is used then the children can attach it to the mast using thread, staples, tape or glue.

Test the vehicle. Design a test to find out which land yacht travels the furthest. The children can use different sources of moving air, such as a

- hair dryer
- bellows
- fan.

The children should record their results. They should consider why some land yachts moved further than others. Consider how to improve the design by using different shapes and materials.

Exemplar 46

Designing and making a pulley system

Initial problem: Can we build a model of a pulley system to help a stonemason lift pebbles from the ground to the top of a model Norman tower?

Background: A simple pulley can be used to move a heavy load. A pulley system can be used to change the direction of a force. Pull downwards on a pulley and it will transfer the force to an upward movement. Pulleys reduce the effort required to raise a load.

A range of solutions may be possible. It is not expected that each child should produce the same outcome.

Assessment: Suitable techniques include

- teacher observation: willingness to try different ideas; willingness to work with others
- portfolio: annotated drawings of work.

Resources: Building bricks, wire coat-hangers, wire cutters, string or nylon thread, nails, screw hooks, thread spools, pebbles, a piece of wood.

Craft-handling skills: This task provides opportunities for the development of the skills of cutting, joining and fastening, making holes and strengthening structures.

Lessons 1 and 2: Exploring, developing skills

Norman castles

A visit to a Norman castle in the local area might initiate discussion on the materials and tools used by stonemasons of this period. The children may pose questions such as

- *How did the Norman builders lift the stones to the top of the castle?*
- *What machines might the Normans have used?*
- *Can we build a model of the pulley system used during Norman times?*

Make a simple pulley

The teacher demonstrates or uses appropriate workcards with illustrations to show the children how to make a simple pulley.

Make a place to hang the pulley. Lay a stick (dowel, broom handle or bamboo cane) over two separated desks. Push the dowel through the open ends of the thread spool. Slide the thread spool onto the centre of the stick. Use tape to secure the stick in place.

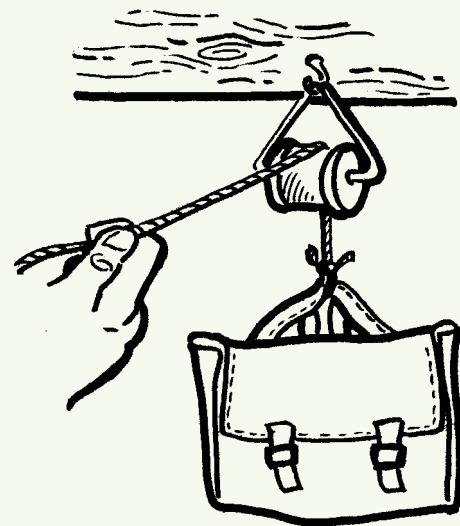

Tie a load to the end of a string. The children can decide on the container used to carry the load. Place the string over the thread spool. Pull the string down to lift the load.

Lessons 3 and 4: Planning, making and evaluating

The children should now be presented with the following problem of making a lifting device that will bring a load up to the roof of a model building. The lifting device should be designed so that loads can be raised and then let down again.

The basic materials which the children will use are thread spools and string. The children will need to consider

- *the shape of the lifting device*
- *how the pulleys will be supported*
- *the number of pulleys to be used*
- *the design of a handle.*

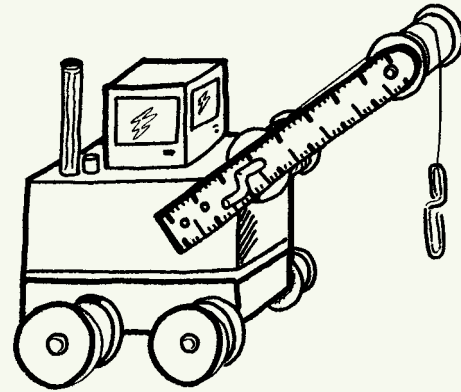

Two rulers with small holes drilled in them can be glued onto a rectangular piece of wood.

A pencil or dowel should be pushed through a thread spool and then placed through the holes at the top of the rulers. Another pulley should be placed near the base. Ensure that the children leave enough room for the thread spool to rotate. Add a handle to turn this thread spool. The string should be wound round this spool and placed over the top pulley. A hook or paper clip can be attached to the string. This will enable the builder to carry the load.

Encourage the children to experiment with different pulley systems to discover the best design.

Evaluating their designs

The children should try out their models using different loads and containers. They should consider how they might improve their models.

Using information and communication technologies

Information and communication technologies can be a greatly enriching resource in the teaching and learning of science. Among the ways in which ICT may be used are the following:

- Data-handling programs can be used by children to record and analyse substantial records or bodies of information. For example, children investigating the most common eye colour in the class or school can enter data about every child. They can then use the computer to analyse the data, identify patterns and produce their findings in graphical form. This encourages children to focus on analysing and interpreting the results of their investigations rather than on producing accurate hand-drawn graphs.
- Many interactive programs that are based on scientific topics are available for primary pupils. These programs allow children to simulate projects, where they will be provided with opportunities to carry out investigations, formulate hypotheses, control variables, evaluate results and plan tests. Interactive programs support experimental work in topics where it might be difficult to organise children to work scientifically, for example conducting experiments with heat or exploring the internal organs of the human body.
- Word-processing and drawing programs provide pupils with another means of communicating and presenting their scientific information and findings. By allowing drafting, editing and correction to be completed so readily, computers can encourage the child who may not find conventional written work satisfactory.
- The internet provides children with access to a range of sources of scientific and technological information. Many science centres, interpretative centres, science museums, industries, Government departments, meteorological agencies and other bodies have worldwide web pages. Children can visit these web sites via the internet.
- The internet can be used as a communication tool to link schools and pupils nationally and internationally. Schools that have a home page can communicate with others using the internet. Other schools use electronic mail to send typed messages from one computer to another. This enables the pupils to share details of their projects and investigations. For example, children can collect, compare and share their observations on weather and the seasons.

- Computer programs can enrich the range of sources and information available to the children. Many CD-ROMs enable children to access vast amounts of information and to extend their experience of a range of objects and events through video and interactive simulations.
- Sensors attached to the computer can help children to extend the range and sensitivity of information that they can measure. Sensors that detect and measure temperature, light, sound, position, humidity or pressure enable children to measure variables that they may previously have been unable to quantify. These sensors display the data on screen as the children are working. This facilitates the evaluation of findings as the investigation is proceeding.



Looking at children's work

The teaching approaches described in the methodologies section of these guidelines may be used by teachers to provide a range of learning experiences for their pupils. Children's participation in these activities, their questions, predictions, hypotheses, discussions, explanations, drawings, models, writings and artefacts provide important information about their progress in achieving the objectives of the science curriculum.

This information is crucial to the teacher's professional judgement about how successfully pupils are learning. A number of techniques will be used in collecting and recording information about pupil progress in science. Each has its contribution to make in assisting the teacher in assessing progress, identifying difficulties, communicating to the pupil, parents and others and in planning further learning for the child.

Teacher observations

Science, by its nature, will involve children in practical investigative activities. Consequently assessing children's work will be carried out while the pupils are undertaking investigations and is dependent on observation by the teacher of children as they undertake investigative work. Observations may be made as children undertake activities or investigations, engage in discussion, plan experiments or interact with other pupils and the teacher. Although watching children during practical science tasks will provide information about their grasp of scientific knowledge, observations are particularly valuable in assessing the

extent to which children have developed appropriate scientific skills of working and attitudes.

Some of the details of children's learning may emerge in an incidental or spontaneous way. At other times teachers may decide to look out for particular behaviours, abilities or interactions. For example the teacher may choose to concentrate on the way in which children identify variables as part of planning an investigation. It may be helpful in advance to identify the expected outcomes of the learning situation. This will facilitate a more structured assessment and will enhance the observations made.

Much of the information obtained through the teacher's observations will not be written down but noting significant aspects of some children's progress or gaps in their scientific knowledge and/or skills may help in the planning of future work for the individual, group or class. Notes might be kept in a simple notebook or diary or on a sheet for the topic, group or class involved. Teacher's observations complement other assessment tools so as to produce a much more comprehensive view of the child's learning in science.

Teacher-designed tasks and tests

Teachers will use a wide range of activities to introduce children to the units of the science curriculum, to allow them to work scientifically, to develop the skills required for designing and making and to reinforce knowledge and develop positive attitudes towards science and technology. The

activities will involve observing both inside and outside the classroom, predicting outcomes, asking questions, designing and making models or structures, estimating, measuring and comparing, analysing objects and processes, hypothesising, recording and communicating in oral, pictorial, model, written and computer format. The active learning situations in which these will take place can be used to assess the progress of individuals and groups and can facilitate the evaluation of the development of children's skills and attitudes.

Exploring and undertaking investigations in the environment will provide crucial information about children's awareness of the diversity of living things, their appreciation of the interdependence of living and non-living aspects of the environment and their awareness of the need to protect and conserve environments. Visiting sites of interest such as farms, factories, quarries will reveal much about the children's understanding and appreciation of the applications of science and technology to society.

The way in which children undertake, carry out and complete investigations in science will provide important information about the pupils' ability to work scientifically. The degree to which children observe accurately, annotate drawings, ask questions, predict outcomes, suggest hypotheses, identify variables and make assessments and judgements from the evidence available will be an important measure of the extent of their grasp of scientific knowledge and skills. Children's

willingness to suggest and test ideas about the events and the objects which they observe will be indicative of their attitudes of open mindedness, confidence and flexibility to work in open-ended situations. Children's pictorial and written work, their models and representations and their communication in other forms should provide opportunities for them to demonstrate their knowledge and understanding of the physical world and their abilities to work scientifically.

Concept-mapping

Concept maps are one of a range of tools which teachers can use to gather information about children's ideas. Concept maps can be used as a tool for learning as well as a tool for assessment. They provide children and teachers with a method of recording and discussing children's ideas about different scientific concepts.

Concept maps are schematic representations of relationships between concepts. Usually the starting point for drawing a concept map is a list of concept words which are known to the children and which can be linked together. It is best to draw up the list with the children and it should only include words thoroughly familiar to them. They can then be asked to draw lines and write joining words on the lines. For children in *infant* and *junior classes* concept-mapping cards with pictures can be used. The results can be analysed to give insight into the relationships which the children see

between things. The value of concept maps is enhanced if they form the basis for discussion and questioning between the individual child and the teacher.

Concept maps compiled at the start of the topic may indicate the level of understanding of the children and the misconceptions and gaps in their knowledge. Concept maps show a large body of information and can help to inform future teaching strategies. They are particularly useful in evaluating the learning that has occurred during a teaching programme. Children can complete concept maps at the end of the topic and these can give an indication of whether or not they have altered or

changed their ideas and whether anything has been learnt or understood.

Work samples, portfolios and projects

The collection of samples of the children's work in portfolios provides one of the most important tools of assessment in science and SESE. The portfolio should contain samples of work that reflect a wide range of tasks which may be compiled by the teacher or older child, enabling balanced monitoring of the child's progress in knowledge and skills to be made in the context of the scientific topics with which he/she is familiar. Samples may be maintained by the child and/or teacher in simple folders or wallets.

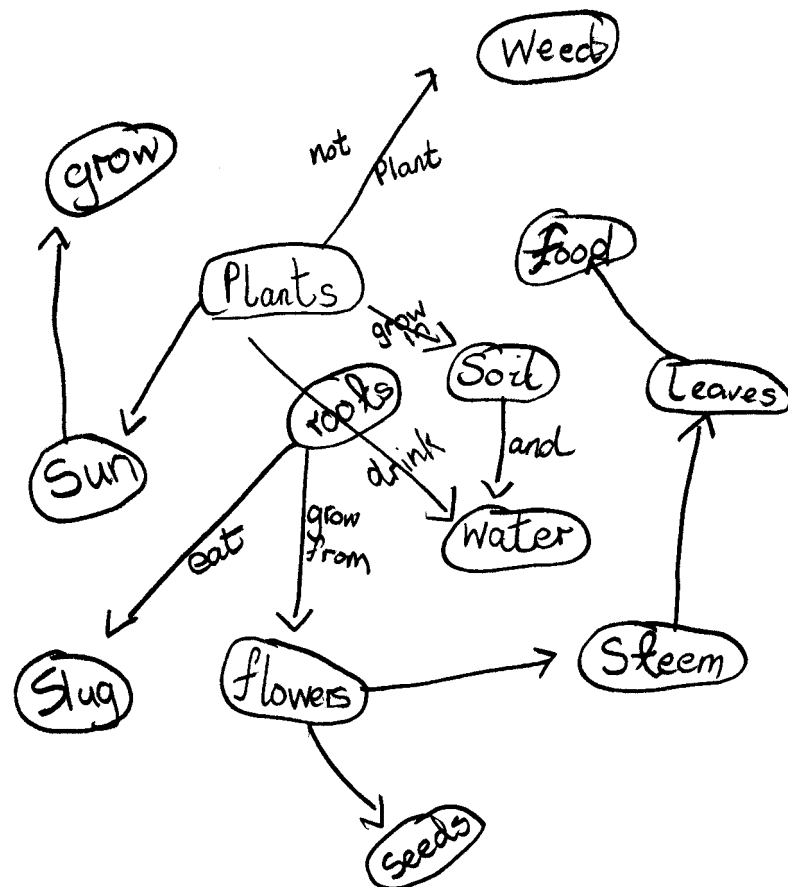

Sample of a child's concept map based on the topic of plants.

Science copybooks, diaries, audio tapes, computer disks, models and artefacts might be included in the portfolio.

If work samples, portfolios and projects are to assist teaching and learning they must remain manageable, and so only the most significant items need to be kept. Samples should be retained when they

- show that particular objectives have been achieved, for example at the end of a unit of work
- mark significant progress in the application of a scientific skill, for example, if a child demonstrates the ability to identify some of the variables required for a fair test or can select the most relevant observations for an investigation
- indicate a weakness or gap in the child's knowledge or skills, such as the poor understanding of the variety of food chains in an ecosystem
- indicate significantly greater progress or a breadth of understanding beyond the content of the lessons.

Samples should have attached the name of the child, the date and the help, if any, the child was given in completing the task. The cumulative record of the child's work, some of which may be selected by the child, allows the teacher to make an informed professional judgement about the child's progress and his/her readiness for further learning experiences. It will also provide an excellent basis for reporting to parents and others. The contents of portfolios can form the basis of end-of-

term displays for parents and can inform the assessment of the child's progress which is recorded and reported on pupil records or pupil profiles.

Portfolios also have a role to play in helping the teacher to review and evaluate the content, methodologies and approaches which he/she has used over a term or year. Work samples which demonstrate the effectiveness of particular approaches or weaknesses in children's learning provide important information for the planning of future work. The analysis of portfolios from a range of children and classes by groups of co-operating teachers could lead to the sharing of teaching experience and the development of a common approach to the assessment of science within the school. It may also enhance the reliability of pupil assessment.

Curriculum profiles

Curriculum profiles provide a way in which the child's progress can be assessed and recorded using indicators of achievement. These indicators, sometimes grouped in sets, attempt to summarise the range of knowledge, skills and attitudes which might be expected at various stages in the child's progress.

By marking, highlighting or shading these indicators as they are achieved by pupils, a record may be kept of the child's progress. Reviewing the child's portfolio of work and other tasks completed by him/her will help the teacher to update the profile from time to time, and the curriculum profile can provide the information needed for the child's end-of-year pupil profile card.



Section 6

Appendix

Resources for teaching and learning science

The provision of a range of resources will be necessary to enable children to undertake investigations in science. It is recommended that individual schools draw up a list of equipment required to implement the programme for science which is envisaged in the school policy.

Many aspects of the science programme require materials (e.g. scissors, glue, ruler, string, paint) that are used in other areas of the curriculum. Some science topics will require consumable materials such as sand, sugar, salt or dried foods. Other topics will require items of domestic reclaimable waste which can be readily collected, for example, plastic bottles, jars, tins, lids, thread spools, and yoghurt pots.

Table 1 identifies materials which may be required to implement the various strands and strand units of the science programme. *Table 2* lists the equipment and materials which may be essential for the implementation of a designing and making component of the curriculum. Some of these materials may only be obtained from specialist science suppliers. Individual schools should decide which of these items are pertinent to their needs.

Table 1 Resources required for the science programme

Strand and strand units	Resources
Living things	
<i>Myself/Human life</i>	<ul style="list-style-type: none">• mirrors (plastic)• metre sticks• height chart• thermometer• measuring tape• bathroom scales
<i>Animals and plants</i>	<ul style="list-style-type: none">• flower pot• insect cages• small trowels• aquarium tank• old spoons• sheets of perspex or plastic• watering can• plastic tubing

Table 1 contd.

Strand and strand units	Resources
Living things	
<i>Animals and plants</i>	<ul style="list-style-type: none"> • hand lenses • nature viewers • binocular microscope • pooters • binoculars • magnispectors • bird table
Energy and forces	
<i>Magnetism and electricity</i>	<ul style="list-style-type: none"> • magnets (selection to include bar, button, horseshoe) • screw-in bulb holders • bulbs and appropriate batteries • iron filings • crocodile clips • needles • wires • compasses • electric buzzers • a range of magnetic materials • electric bells • electric motor • a selection of metals • wire stripping pliers • steel wool • screwdrivers
<i>Light</i>	<ul style="list-style-type: none"> • torches • curved mirrors • plane mirrors • glass blocks and triangular prism • shiny objects that will act as mirrors: spoons, biscuit tin lid, sheet metal • transparent, translucent and opaque materials • colour filters • candles • old spectacle lenses • projector
<i>Heat</i>	<ul style="list-style-type: none"> • thermometers • candles

Table 1 contd.

Strand and strand units	Resources
Energy and forces	
<i>Sound</i>	<ul style="list-style-type: none"> • tuning forks • rubber bands (different sizes and thicknesses) • guitar strings
<i>Forces</i>	<ul style="list-style-type: none"> • wheeled toys • oil, grease, polish, wax • inclined plane • sandpaper • springs • mechanisms: tongs, pliers, nutcracker, toys, old clock etc. • weights • marbles • balls • construction sets such as Meccano: wheels, pulleys, axle rods, gears • timers • stop clocks and watches • balloons • plastic syringes • pulleys
Materials	<ul style="list-style-type: none"> • funnels • polystyrene sheets, blocks, balls and beads • sieves, plastic, various meshes • samples of different fabrics and fibres • food colourings • samples of soaps and detergents • dyestuffs • materials from the kitchen or bathroom (sugar, salt, soda, chalk, oil, soda water, lime water, tea, coffee, bath salts, flour) • samples of different metals • pebbles, stones, bricks and rocks • samples of different woods and wood products • samples of different types of paper (blotting paper, tissue paper, paper towels, waxed paper, greaseproof paper, newsprint) • corks.

Table 2 Equipment and materials required for designing and making

Strand units	Resources
Exploring	<ul style="list-style-type: none"> • construction kits such as Lego Technic, K'Nex, Fischer Technik, Meccano, Master Builder • mechanisms – egg beater, bicycle pump, jack, hinges, toys
Making	<ul style="list-style-type: none"> • hammer and nails • nuts and bolts • hacksaws and spare blades • wood glues • clamp • sandpaper • screwdriver and screws • craft knife • hand drill • rulers and scissors • clips • spanners • needle • rotary cutter • G clamp
Consumable materials	<ul style="list-style-type: none"> • Plasticine • Plaster of paris • clay • a range of fabrics and fibres • fasteners – bulldog clips, paper clips, hair clips, clothes pegs
	<ul style="list-style-type: none"> • corriflute • soft woods • foil • metals • acetate • plastic • rubber • dowels of various lengths and thicknesses • thin wire • string and threads • adhesives • paints
	<ul style="list-style-type: none"> • Domestic reclaimable waste • plastic bottles of various sizes • plastic straws • aluminium foil • thread spools • tins • range of empty boxes, lids, containers and tubes • coat hangers • polystyrene blocks and beads • scrap cord and board • corks of varying sizes.

Source references for the curriculum and guidelines

Collins, Martin	<i>Urban Ecology</i>	London, Cambridge University Press, 1984
Electricity Council	<i>Electricity for Life: Science Pack for Primary Schools, Unit 1: At Home and Around Us</i>	Electricity Council, England, n.d.
Finch, Irene	<i>Nature Study and Science</i>	Longman, 1981
Harlen, Wynne (ed.)	<i>Primary Science: Taking the Plunge</i>	London, Heinemann Educational, 1985
Harlen, Wynne	<i>Progress in Primary Science: Workshop Materials</i>	London, 1990
Irish National Teachers' Organisation	<i>Social and Environmental Studies in Primary Education in Ireland</i>	Dublin, INTO, 1992
Jarvis, Tina	<i>Children and Primary Science</i>	London, Cassell Educational, 1991
Madden, Paddy	<i>Go Wild at School</i>	School Wildlife Assoc., Dublin, 1996
National Curriculum Council	<i>Knowledge and Understanding of Science: Forces: A Guide for Teachers</i>	York, NCC, 1992
National Curriculum Council	<i>Knowledge and Understanding of Science: Electricity and Magnetism: A Guide for Teachers</i>	York, NCC, 1993
National Curriculum Council	<i>Teaching Science at Key Stages 1 and 2</i>	York, NCC, 1993
Northern Ireland Curriculum Council	<i>Science: Guidance Materials</i>	Belfast, NICC, 1990

Nuffield Primary Science: Science Processes and Concept Exploration	<i>Infant Teachers' Guides: Forces and Movement Materials The Variety of Life</i>	London, Collins Educational, 1996
	<i>Junior Teachers' Guides: Forces and Movement Light Living Processes Living Things in Their Environment Materials The Variety of Life</i>	
O'Connell, Catherine	<i>Peatlands and the Primary School Curriculum</i>	Dublin, Irish Peatland Conservation Council, 1994
O'Doherty, Carmel	<i>Primary Science Starts Here</i>	Limerick, Primary School Science Project, 1994
An Roinn Oideachais	<i>Safety in School Science</i>	Dublin, An Roinn Oideachais, n.d.
Scottish Consultative Council on the Curriculum	<i>Environmental Studies 5–14 Exemplification: Science, Understanding Earth and Space; Understanding Living Things and the Processes of Life; Understanding Energy and Forces</i>	Dundee, SCCC, 1996
Tree Council of Ireland	<i>Tree Day: A Resource Pack on Trees for Primary Schools</i>	Dublin, Tree Council of Ireland, 1997

Glossary

air-resistance	a frictional force that opposes the movement of an object through the air
amphibian	a type of animal that spends part of its life cycle in water and part on land; cold-blooded with a backbone
animal	a type of living organism that moves about in search of food and is not a plant; single-celled organisms (as seen under a microscope) are not considered animals
battery	two or more electric cells that produce electricity; this happens when the chemicals within the battery react together; the voltage of a battery depends on the number of cells it contains: more cells mean greater voltage
biodegradable	capable of being broken down by bacteria or fungi
blood	the fluid that flows through the heart, veins and arteries of animals; it carries oxygen as well as other substances in the arteries and carries waste products in the veins
breathing	the process of taking in oxygen from the air and releasing of carbon dioxide to the air through the lungs, gills or other structures
buoyancy	the upward thrust experienced by objects when they are placed in a liquid
carbohydrates	substances such as sugar and starches; green plants make carbohydrates through the process of photosynthesis
carnivore	an animal that eats meat or flesh
chemical change	a change in materials that produces a new substance; the change is permanent
chlorophyll	the green pigment in plants, necessary for photosynthesis

circuit	the complete path of an electric current around a series of wires and connections; if there is a break in the circuit the current will not flow
classification	the grouping together of plants, animals, rocks or other objects that have similar characteristics
community	all the organisms that live together in a habitat
competition	the struggle among organisms for a resource that is in short supply, such as food, water, oxygen, space or mates
condensation	the change of a gas into a liquid by cooling; for example, vapour from a boiling kettle hitting a cold kitchen wall condenses into liquid
conduction	the movement of energy through a substance
conductor	a material that transmits heat, electrical or other kinds of energy
control	see 'experiment'
current (electric)	a flow of charge; electrons are the charge carriers; a current in a metal consists of a flow of electrons (electricity) from the negative terminal of the battery to the positive terminal; however, we usually say that current flows from positive to negative; measured in amperes or 'amps'(A)
decomposer	organisms such as bacteria and fungi; they break down the dead remains of organisms into simpler substances, which are returned to the soil
diaphragm	a sheet-like muscle that separates the chest cavity from the abdomen in mammals; important in breathing
digestion	the process by which large food particles are broken down and made soluble with the help of enzymes and our teeth

dissolving	the mixing of a substance with a solvent, for example sugar mixed with water, to form a solution; children sometimes confuse the terms melt and dissolve
ear	the organ of hearing; the external part of the ear leads to a canal, at the end of which is the ear drum; the ear drum is connected to three bones, which in turn are connected to an oval window; the ear is connected to the brain by the auditory nerve
ecology	the study of ecosystems
ecosystem	a community of organisms and their relationships with each other and with their environment
egg	a female reproductive cell in an organism
electromagnet	a magnetic material, surrounded by coiled wire, that acts as a magnet when an electric current passes through the wire
electron	one of the particles of which an atom is made up; electrons are negatively charged
energy	the ability to do work; light energy, electrical energy and sound energy are all different forms
evaporation	the changing of a liquid into a (gas) vapour by using heat or moving air, for example boiling a solution and driving the water off as steam, or a puddle being changed into vapour by the wind
excretion	the release of waste materials from an organism
experiment	a procedure causing a change in what is being tested together with an identical untested control
explorations	all activities that relate to an investigation, including unstructured, unplanned preliminary activities, such as play
eye	the organ of sight; the visible parts include the clear outer cornea, the coloured iris and the pupil; the eye also contains a lens, and the back of the eye is covered by the retina

fair test	a test in which everything about the things being tested is equal, except the item being tested
fertilisation	the joining together of a male and female reproductive cell to form a new organism
filter	an object such as a sieve or a strainer that will separate an insoluble solid from a liquid when the mixture is passed through it; or a transparent material that allows some light to pass through it
filtration	a technique for separating a solid or solids from a liquid in a mixture by passing through a filter, for example tea being strained through a strainer
floating	the tendency of an object to remain on the surface of a liquid; an object will float if its density is less than that of the liquid; the weight of a floating body is equal to the weight of fluid displaced; the force up and the force down on the body are equal
flower	the reproductive part of flowering plants, which contain the sex organs of the plant, i.e. the carpel (female) and the stamen (male); the carpel consists of the stigma, style and ovary; the stamen consists of the anther and the filament; petals, which are usually brightly coloured, help to attract insects to pollinate the flower; sepals, which are usually green and lie outside the petals, and protect the flower in the bud stage
food chain	the transfer of energy from one organism to another within a habitat or ecosystem; shows the feeding relationships between organisms; a simple food chain is grass › rabbit › fox
food web	a linked series of food chains
force	anything that causes a change in the velocity of an object. Force is loosely understood as being a 'push' or a 'pull'. It can make an object speed up, slow down, stop, change shape or change direction or hold an object in place

fossil fuel	fuel formed from the remains of living organisms millions of years ago, for example coal, oil and natural gas
friction	a force that opposes movement
fuse	a device to prevent too large an electric current passing through a circuit; consists of a piece of thin wire that melts if it becomes heated; this breaks the circuit and acts as a safety device
germination	the process that occurs when a seed or spore begins to grow into a mature plant; germination requires moisture, oxygen and a suitable temperature
gravity	a force of attraction between all bodies in the universe; the force of attraction between objects depends on their mass; the greater the mass of an object the greater the force of attraction
habitat	the place where an organism lives; it provides a particular set of conditions for life; it may be large (a field) or small (a leaf)
heart	an organ that pumps blood around the body; in the adult human the heart rate is about 70 beats per minute, but in a baby it will be much faster; blood travels by means of a network of vessels; blood leaves the heart through arteries and returns to the heart in veins
heat transfer	the way in which heat is moved: in solids by conduction, in liquids and gases by convection, and from a hot object like the sun or a stove by radiation
herbivore	an animal that eats plants only
humus	a brown or black fibrous material formed from the remains of dead plants and animals; it helps soil particles to stick together and is important in soil fertility
hydraulics	the pressure of liquids that can make something work

hypothesis	an idea that can be tested: a supposition put forward in explanation of observed facts; the prediction is qualified by a tentative explanation
insulator	a material or substance that will not allow heat to pass through it or one that will not allow electricity to flow through it
investigations	activities where ideas, predictions or hypotheses are tested and conclusions are drawn in response to a question or problem
joint	a connection formed where one bone meets another; in most cases the bones can move freely, for example hip, shoulder and elbow
key	a series of questions that leads to the identification of organisms or other unknown items
lens	a piece of glass or transparent material that causes light to change direction as it passes through it; lenses can be different shapes, for example concave and convex lenses
lever	a rigid bar that can be turned freely about a fixed point; levers are simple machines, they make work easier
light	a form of energy that travels in rays; light travels at approximately 300,000 km/s; white light is a mixture of light of every wavelength, that is, of all colours
luminous	giving out its own light, for example the sun and other stars
lungs	the respiratory organs in humans and many other animals; the respiratory system includes the nasal passages and mouth, pharynx, larynx (voice box), trachea (wind-pipe) and bronchi
machine	a device that takes in some form of energy and changes it into another form that is more suitable for the desired purpose or work, for example an electric motor lifting a weight; electrical energy changes to kinetic energy

magnet	a material that produces a magnetic field around itself; can be shown by sprinkling iron filings around the magnet; there are poles at the ends of magnets: these are the north-seeking and south-seeking poles; like poles repel each other, whereas unlike poles attract; magnets are made in a variety of shapes and sizes; most materials are non-magnetic, but metals such as iron, nickel, cobalt or alloys of these, such as steel, are magnetic; a compass is a free-swinging magnet
mammal	a warm-blooded animal with a backbone (vertebrate), usually with a covering of hair or fur, that produces live young and feeds them on milk; the duck-billed platypus and the spiny ant-eater are exceptions, as they lay eggs
mass	mass describes the amount of matter in an object; measured in grams (g)
material	matter from which other things can be made; materials can be classified in many different ways, for example natural such as wood, or synthetic, such as plastics, polyester or stainless steel; materials can be classified according to their uses or their properties such as metals, plastics, textiles and others
matter	anything that takes up space and has mass; all substances and materials can be called matter; solid, liquid and gas are the terms used to describe the three states of matter; it is possible to convert one state into another by either heating or cooling
micro-organism	a living organism that can only be seen under a microscope
mineral	inorganic chemicals needed in small amounts by plants and animals, for example calcium, iron and copper; can also refer to anything extracted by mining, for example copper and gold
mixture	formed when two or more substances are added together, for example salt and water; the substances are not chemically combined and may be separated again

newton	see 'weight'
non-renewable	energy sources that are not continuous and cannot be renewed naturally; examples are fossil fuels (gas, coal, oil, turf)
nuclear energy	released during the splitting (fission) or joining (fusion) of the nuclei of some atoms
observation	using the senses to obtain information about objects and events
organ	a part of the body, such as the heart or stomach, made of several different tissues, all working together to perform a specific function
organism	a living animal, plant, fungus or micro-organism
opaque	not letting light pass through: neither transparent nor translucent
photosynthesis	the process by which green plants manufacture their own food from carbon dioxide and water, using the sun's energy, which is trapped by the green pigment (chlorophyll) in the plant
physical change	a change in which no new substance is formed; the change can be in shape, form or state, for example wood being cut or ice melting
pitch	highness or lowness of a note; sound is caused by vibrations; the pitch of a note is a measure of the frequency of vibration of the source producing the note
plant	an organism made up of many cells; the cells have a wall and a nucleus; they manufacture their own food by photosynthesis; plants respire, grow, reproduce and respond to stimuli just like animals but do not move from place to place
plastic	a synthetic material; raw material is usually derived from oil; can be moulded into shape when heated and sets hard when cooled

pole	the point of a magnet where the magnetic force is strongest; every magnet has a north and a south pole
pollen	grains, usually yellow or orange, produced by the anther; contains the male reproductive cells of flowering or coniferous plants
pollination	transfer of pollen from the anther of a stamen to the stigma of a carpel; self-pollination is when this happens within the same plant; cross-pollination is more common and is when the pollen comes from another plant of the same species; pollination is usually effected by insects or wind
pooter	a device used to collect insects and other small animals from the bark of trees and shrubs and from leaves; consists of a jar from which two plastic tubes emerge
population	the total number of organisms of a species within a particular habitat, for example, the daisy population of a field
power	the rate at which work is done, that is, the amount of work done per second; the unit of power is the watt (W)
primary colour	the primary colours of light are red, green and blue; white light is obtained by mixing all three in equal proportions; mixing two primary colours gives one of the secondary colours, yellow, cyan or magenta; the primary colours of paint are red, yellow and blue
prism	a triangular block made of glass or plastic; can be used to change the direction of light or to split light into the colours of the spectrum
protein	one of the major types of food; used for growth and repair in the body; body-building material
quadrat	a small area, generally about 1 metre square, that shows all the plants growing in that area; can be made from pieces of wire, string or wood

reflect	a ray of light hits off something and bounces back; all objects reflect light to some extent, some better than others; a mirror reflects light very well; sound can also be reflected, and a common example of this is an echo
refraction	the change of direction of light when it passes from one medium to another, for example, from air to glass, water or plastic
renewable energy	energy from sources such as tide, wave and biomass
reproduction	the formation of new individuals; sexual reproduction involves the joining (fusion) of two sex cells; only one organism is involved in asexual reproduction; taking cuttings of plants is an example of asexual reproduction
resistance	a measurement of the ability of a substance to reduce the flow of current through it; measured in ohms
resistor	a device that controls the current flowing in a circuit; resistors are used in radios, record players and televisions
respiration	the process by which living things obtain energy from food; all living things respire
respiratory system	in humans consists of windpipe, bronchi, lungs, diaphragm and nose
rusting	a chemical reaction that occurs in iron or steel when both air and water are present; the general term is corrosion; can be prevented by methods such as painting, oiling and greasing
shadow	a dark area formed when light strikes an opaque object
soil	a substance composed of particles of different size; formed by weathering of rock; contains water, humus, air, minerals and living organisms

solution	a mixture of a solute and a solvent, for example a sugar and water solution, where the solute is the sugar and the solvent is the water
sound	a form of energy; all sounds come from something that is vibrating; sound travels through air, solids and liquids; the speed of sound in air is about 344 m/s
species	a set of organisms that share many characteristics in common; they can breed with each other to produce fertile offspring; examples of species are humans, dogs, cats, buttercups and daffodils
spectrum (visible)	the range of colours produced when light is passed through a prism; colours can be seen when white light is split by droplets of water; forms only a small part of the whole electromagnetic spectrum; this spectrum includes radio waves, microwaves, X-rays and gamma rays, among others
spore	a microscopic reproductive cell; produced by fungi, mosses, ferns and, in general, plants that do not have seeds
static electricity	an electric charge that builds up on the surface of a material; this build-up can happen by rubbing one material against another; electrons are rubbed off one of the materials which then becomes positively charged, while the other material, which gains the electrons, becomes negatively charged; the two materials then attract each other; thunderstorms are caused by static electricity
switch	a device used to make or break circuits; it stops the flow of electricity in a circuit
temperature	a measurement of how hot it is; thermometers are used to measure temperature and are usually marked in degrees Celsius (°C)
theory	a set of general statements that provide feasible explanations for certain phenomena; can be used to predict the occurrence of certain events

transect	a line of string or some other material along which vegetation or animals are studied
translucent	allowing some light through; objects cannot be seen clearly through such material; frosted glass is an example of a translucent material
transparent	material through which light passes and allows an object to be seen clearly
variable	the characteristic in an investigation that the investigator decides to change on a systematic basis
variation	the differences in characteristics that appear within a species: for example, humans have different coloured hair, eyes, skin and size
vertebrate	animals with a backbone and a brain enclosed in a skull
voltage	potential difference; measured in volts
water vapour	water in the gaseous or vapour state
watts	a unit of power 1 kW = 1,000 W
weight	the downward force acting on a body due to the effect of gravitational force; measured in newtons (N)

Membership of the Curriculum Committee for Social, Environmental and Scientific Education

These guidelines have been prepared under the direction of the Curriculum Committee for Social, Environmental and Scientific Education established by the National Council for Curriculum and Assessment.

Chairpersons

Michael Dee	Irish National Teachers' Organisation
Angela Griffin (<i>from 1995</i>)	Irish National Teachers' Organisation
Helen Kennedy-Martin (<i>to 1995</i>)	Irish National Teachers' Organisation

Committee members

Br Thomas Costello	Teaching Brothers' Association/Association of Primary Teaching Sisters
Peadar Cremin	Management of Colleges of Education
Margie Cullen	National Parents Council—Primary
Marie Danaswamy(<i>to 1995</i>)	National Parents Council—Primary
Teresa Farry (<i>from 1996</i>)	Irish National Teachers' Organisation
David Fitzgerald	Catholic Primary School Managers' Association
Henry Goff	Irish National Teachers' Organisation
Angela Griffin	Irish National Teachers' Organisation
Kathleen Horgan (<i>to 1996</i>)	Irish National Teachers' Organisation
Jim Hourihane	Irish Federation of University Teachers
Siobhán Hurley	Irish Federation of University Teachers
Helen Kennedy-Martin	Irish National Teachers' Organisation
Frankie McGrath (<i>to 1995</i>)	Irish National Teachers' Organisation
James Malseed	Church of Ireland General Synod Board of Education
Sheelagh Morrow	Church of Ireland General Synod Board of Education
Patrick Murchan	Catholic Primary School Managers' Association
Éamonn Ó Breacáin	Department of Education and Science
Tomás Ó Briain	Irish National Teachers' Organisation
Colm Ó Ceallacháin	Department of Education and Science
Micheál Ó Cinnéide (<i>from 1995</i>)	National Parents' Council—Primary
Micheál Ó Mathúna	Department of Education and Science
Sr Mairéad Rabbitte	Association of Primary Teaching Sisters/Teaching Brothers' Association
Brian Tubbert	Irish National Teachers' Organisation

Science adviser

Paula Kilfeather

Education officers

Harold Hislop

Carmel O'Doherty

Membership of the Primary Co-ordinating Committee

To co-ordinate the work of the Curriculum Committees, the Primary Co-ordinating Committee was established by the National Council for Curriculum and Assessment.

Chairperson	Tom Gilmore	
Committee members	Sydney Blain <i>(from 1995)</i>	Church of Ireland General Synod Board of Education
	Liam Ó hÉigearta <i>(from 1996)</i>	Department of Education and Science
	Dympna Glendenning <i>(to 1995)</i>	Irish National Teachers' Organisation
	Fionnuala Kilfeather <i>(from 1995)</i>	National Parents Council—Primary
	Éamonn MacAonghusa <i>(to 1996)</i>	Department of Education and Science
	Fr Gerard McNamara <i>(from 1995)</i>	Catholic Primary School Managers' Association
	Peter Mullan	Irish National Teachers' Organisation
	Sheila Nunan <i>(from 1995)</i>	Irish National Teachers' Organisation
	Eugene Wall	Irish Federation of University Teachers
Co-ordinator	Caoimhe Máirtín <i>(to 1995)</i>	
Assistant Chief Executive Primary	Lucy Fallon-Byrne <i>(from 1995)</i>	
Chief Executive	Albert Ó Ceallaigh	

NCCA Chairpersons: Dr Tom Murphy *(to 1996)*, Dr Caroline Hussey *(from 1996)*

Acknowledgements

In the case of some copyright material the publishers have been unable to contact the copyright holders but will be glad to make the usual arrangements with them should they contact the publishers.

For access and permission to take photographs the publishers make grateful acknowledgement to the following: the boards of management, principals, teachers and pupils of the primary schools countrywide who co-operated with the project.

ISBN 0-7076-6337-7



9 780707 663371



AN ROINN OIDEACHAIS
AGUS EOLAÍOCHTA | DEPARTMENT OF
EDUCATION
AND SCIENCE

